

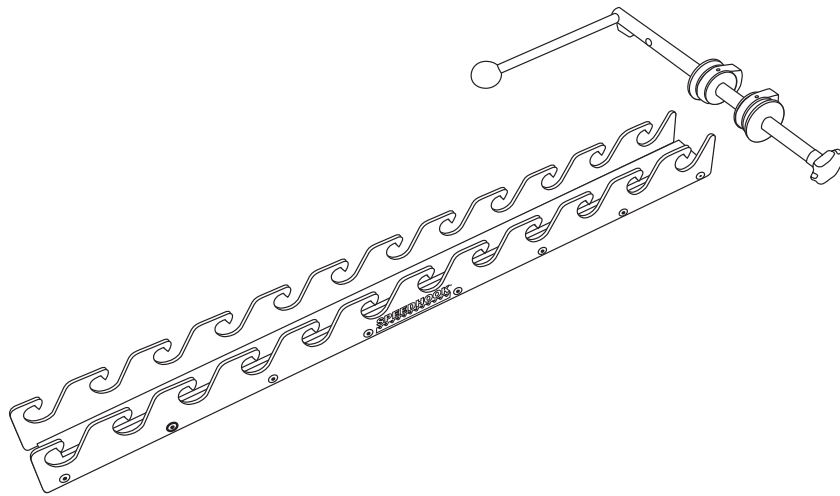

Diamond Tools and Equipment

SpeedHook®

Concrete Cutting System



Hydraulic Saws

OPERATOR'S MANUAL

SYMBOLS & LABELS	4
SAFETY	5
TECHNICAL SPECIFICATIONS	6
SET-UP	
• 823H / 853PRO / 880F4	7
• 813M / 814PRO	8
OPERATION	9
CUTTING TIPS	10
TROUBLESHOOTING	11

THE FOLLOWING SYMBOLS & DEFINITIONS ARE FOUND THROUGHOUT THIS MANUAL AND ARE DESIGNED TO MAKE YOU AWARE OF POTENTIAL HAZARDS OR UNSAFE PRACTICES.

⚠ WARNING

A potentially hazardous situation exists which, if not avoided, could result in death or serious injury.

⚠ CAUTION

A potentially hazardous situation exists which, if not avoided, may result in minor or moderate injury or property damage.

IMPORTANT

A potential situation exists which, if not avoided, may result in product or property damage.

THE FOLLOWING SYMBOLS & LABELS MAY BE FOUND IN THIS MANUAL OR ON THE SAW



Read the operator's manual carefully and understand the contents before you use this equipment.



Always use:

- Protective helmet
- Ear protection
- Protective glasses or full face protection



Wear hand protection

GENERAL SAFETY PRECAUTIONS

- Always wear protective clothing, including hard hat, eye protection, hearing protection, and gloves.
- Avoid loose fitting clothing.
- Perform safety checks before starting each day.
- Always operate tool with solid footing and with both hands on saw.
- Remove or control slurry to prevent slippery conditions while cutting.
- Be sure there are no obstructions (plumbing, electrical conduit, air ducts) and no unnecessary people present.
- Set up a well-marked safety zone with a roped boundary and clear signs.
- Provide adequate ventilation when working in an enclosed area. Breathing exhaust gases is dangerous.

	SpeedHook®
Length	42 in (105 cm)
Width	3.5 in (8.9 cm)
Weight of Rail	18 lbs (8 kg)
Distance from cut line to ϕ of anchors, A	3.25 in (83 mm)
Distance from cut line to ϕ of outside rail, B	1.5 in (38 mm)

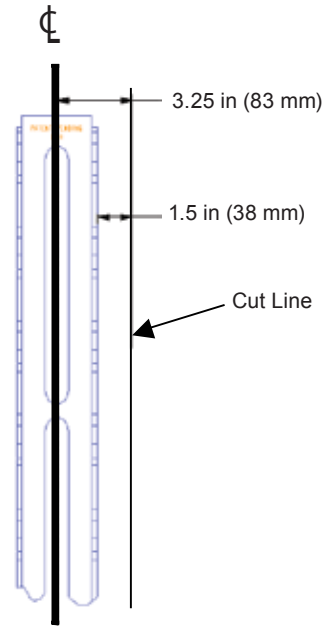

Tools Required:

823H / 853PRO / 880F4 Series Hydraulic Saws

1. Srench

813M & 814PRO Hydraulic Saws

1. 3/16" Allen wrench
2. Pliers

823H / 853PRO / 880F4 HYDRAULIC MOUNTING BRACKET INSTALLATION

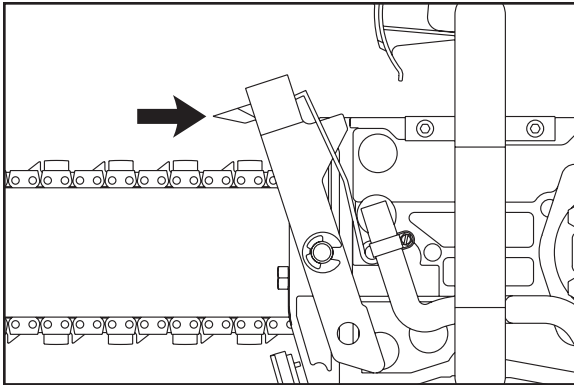

STEP 1
Remove WallWalker® and spring

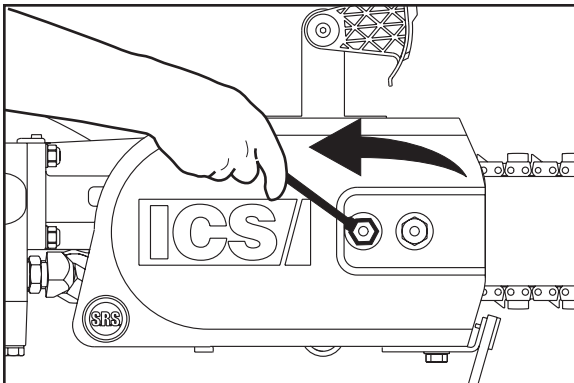

STEP 2
Remove side cover (retain side cover for future use without SpeedHook®)

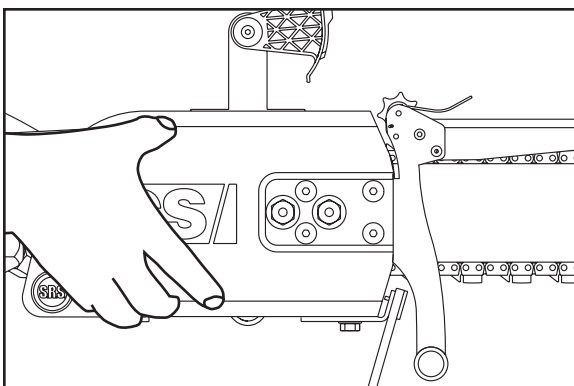

STEP 3
Mount SpeedHook® mounting bracket over bar mount studs

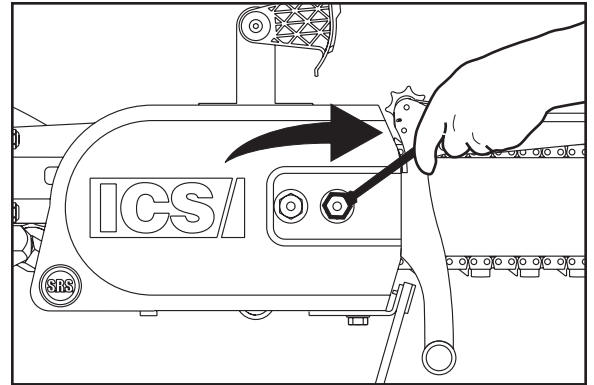

STEP 4
Tension bar and chain as described in the 823H / 853PRO / 880F4 operator's manual

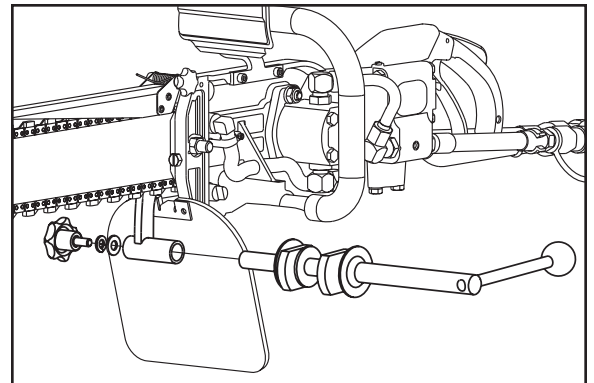

STEP 5
Insert axle into mounting basket as shown and firmly tighten knob

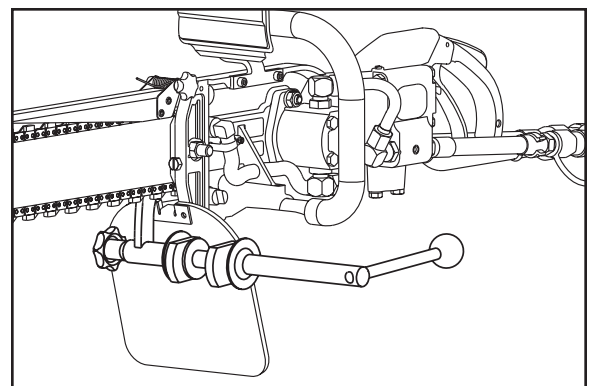

STEP 6
Complete assembly

813M & 814PRO HYDRAULIC MOUNTING BRACKET INSTALLATION

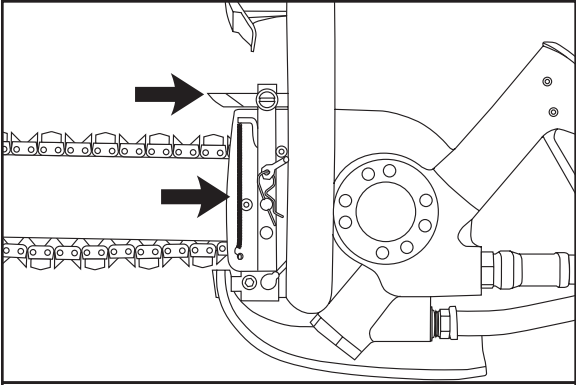

STEP 1
Remove WallWalker® and spring

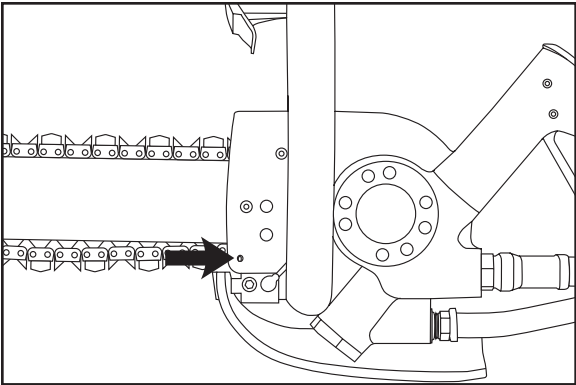

STEP 2
Remove spring anchor

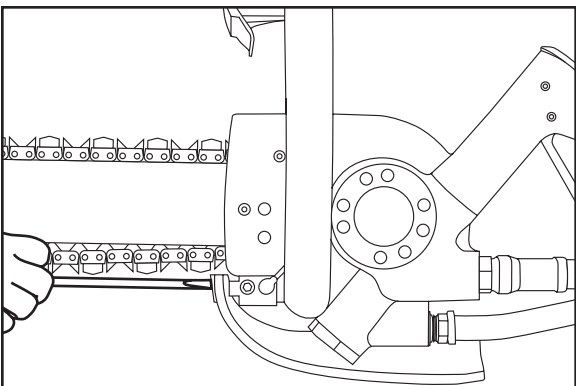

STEP 3
Remove mud flap and bracket

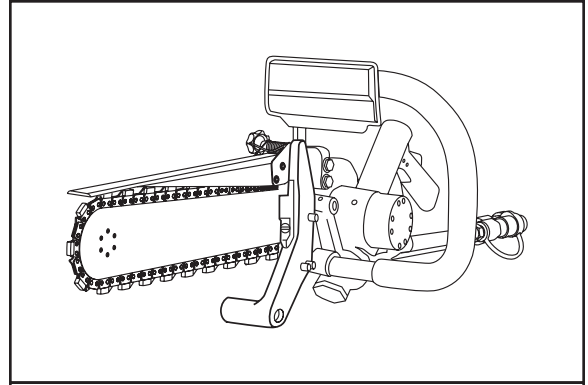

STEP 4
Attach SpeedHook® mounting bracket assembly. *Note: Do not over tighten attachment bolts*

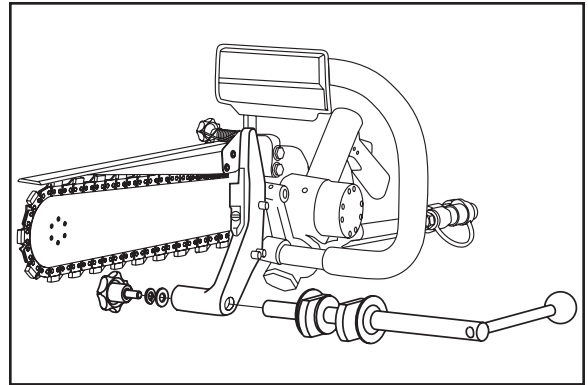

STEP 5
Insert axle into mounting bracket as shown and firmly tighten bolt

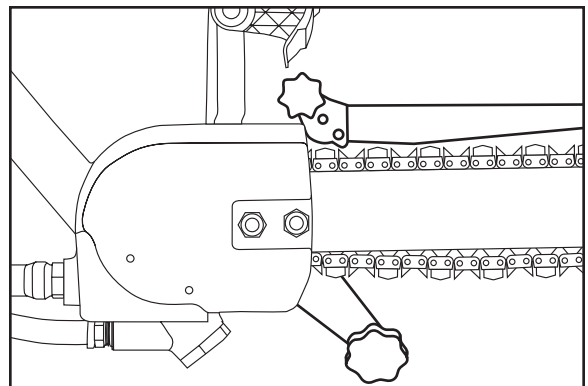

STEP 6
Complete assembly

PLANNING THE CUT

The following steps are recommended to maximize cutting efficiency, productivity and assure safety:

- Outline the cut with a permanent marker.
- Layout concrete anchor marks 3¼ inches (8.3 cm) inside each cut line.
- Set the anchors. Caution: The anchor bolts cannot protrude out of the wall more than 3/8 inches (1 cm) or interference with the SpeedHook® mounting bracket (on the saw) can occur.
- Cutting sequence: Always start with the right-hand side cut first, then the bottom and then the top. Save the left-hand side cut for last. Using this sequence you will only need to reverse the axle for the last cut.
- Be sure cut concrete cannot fall and injure operator or bystanders.
- Check for live electrical wiring near cutting areas or in the concrete to avoid electrocution which can result in death or serious injury.

MOUNTING THE SPEEDHOOK® TO WALL

- Loosely attach the rail to the wall so that the horizontal and vertical adjustments can be made.
- Position the rail so that the scribe line near the bottom of the rail is where you want the cut to end.
- Position the outside of the rail *exactly* 1½ inches (3.8 cm) from the center of the cut line and securely tighten the anchors, using thick fender washers.
- Do not flex SpeedHook® to the wall when gaps exist. Instead, shim gaps between SpeedHook® and wall.

MAKING THE CUT

- Engage the axle into the hook of the rail near the beginning of the cut.
- Rotate lever arm to engage the cams, locking the axle firmly in place.
- Rev up the saw to full RPM.
- Slowly rotate the saw into the wall making sure the cut starts *exactly* on the cut line.
- As the saw approaches the end of its rotation, keep the chain running and index the next set of hooks. It is easier to index if the saw has not reached a full 90 degrees.

SYSTEM CLEAN-UP

- Leave the water on and run the saw for 15 seconds with bar tip down to flush slurry and debris from the system.
- Wash concrete slurry from the saw assembly and SpeedHook®.
- Spray entire SpeedHook®, saw, chain, bar and drive sprocket with a lightweight penetrating oil. This will minimize rust and reduce slurry build-up on saw assembly.

TIPS FOR CUTTING STRAIGHT

- **MOUNTING** - Ensure the SpeedHook® rail is securely fastened to the wall, and that the patent number stamped on centerpiece is facing away from wall. Ensure mounting anchors have not loosened from the concrete. If the rail becomes loose, SpeedHook® will not cut straight.
- **SPACERS** - Use 2 to 3 inch (5 to 7 cm) diameter washers to space the rail off the wall especially when the wall is not perfectly flat. This will reduce warping.
- **ANCHORS** - Only use anchors approved for mounting wall saws.
- **SHORT BAR** - Always use the shortest bar possible to cut through the wall. Long bars are susceptible to deflection, especially when starting the cut.
- **STEP-CUT** - In hard materials or walls over 8 inches (20 cm) thick, cut as much as you can with a short bar then switch to a longer bar to finish the cut.
- **STARTING THE CUT** - Accurately space the rail from the cut and start the cut *exactly* on the cut line.
- **LONG CUTS** - If cut exceeds 42 inches (105 cm), it is possible to stack SpeedHook® rails end to end.
- **FEED PRESSURE** - Start the cut using light feed pressure. Be patient, let the saw and chain do the work. Excessive feed force will cause the bar to deflect and cut crooked.
- **AXLE ENGAGEMENT** - Keep both bearing surfaces of the axle engaged into the *back* of the hooks while cutting. Rotate lever arm 90 degrees to the wall surface until the cams are engaged, forcing the axle toward the back of the hooks. Support the hydraulic hoses when cutting horizontally.
- **AXLE CAMS** - To maximize the life of the cams, avoid engaging the cams against the large Speedhook® rail anchor washers. The washer's sharp edge will gouge the cams, reducing their effective life. If possible, avoid the hook that causes interference between the cams and anchor washers.
- **DRESS BAR RAILS** - At the first sign of a crooked cut, flip the guidebar over (it's reversible). Dress the guidebar rails on a belt sander to make the rail height on each side even again.
- **UPGRADE SPEEDHOOK** - To help cut straighter, with less physical effort, upgrade earlier SpeedHook® to new axle bracket.

TROUBLESHOOTING

- **LOOSE AXLE KNOB** – Lock washer missing or not installed correctly. Lock axle into bracket by reversing the washers (put lock washer against the axle).
- **DIFFICULTY INDEXING** - Keep the saw running at full RPM while indexing. Index before the saw rotates fully 90 degrees into the wall.
- **WATER NOT FLOWING** - Water hose is kinked or supply is not turned on.
- **SLOW CHAIN SPEED** (hydraulic saws) - Be sure the power supply is providing 8 gpm (30 lpm) and 2,500 psi (172.5 bar). The 853PRO Plus requires 12 gpm (45 lpm) *fixed flow*. Also, do not apply excessive feed force.
- **RESTART CUT** - If the cut starts to become crooked, pull out, move down one or two hooks and restart the cut. Connect the two cuts later by up-cutting.

**Further questions?
Call 1.800.321.1240 or
visit our website at
icsdiamondtools.com**

SpeedHook® OPERATOR'S MANUAL

**ICS, Oregon Tool Inc.
4909 SE International Way
Portland, OR 97222
Tel 800.321.1240
icsdiamondtools.com**