

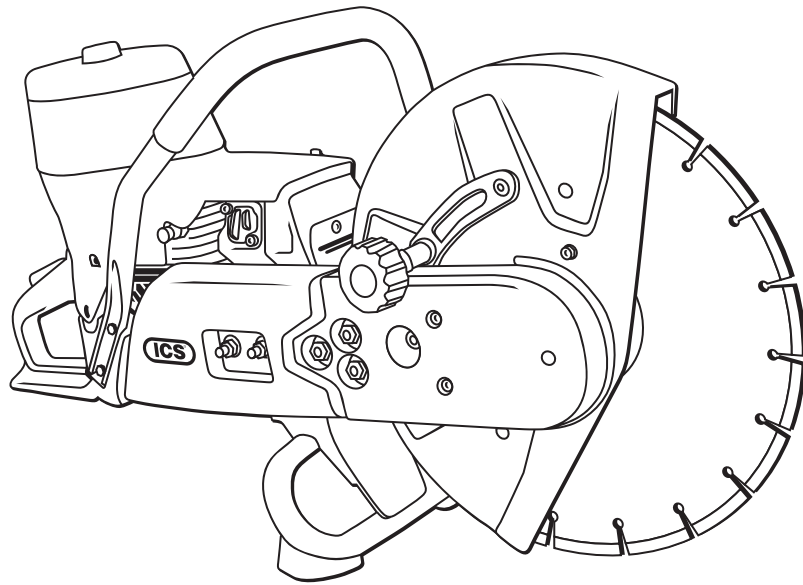

**Diamond Tools and Equipment**

# **RZ60C**



## **OPERATOR'S MANUAL**



<b>SYMBOLS &amp; LABELS</b>	<b>4</b>
<b>SAFETY</b>	<b>6</b>
<b>TECHNICAL SPECIFICATIONS</b>	<b>9</b>
<b>SET UP</b>	<b>10</b>
<b>ADJUST GUARD</b>	<b>12</b>
<b>REVERSE ARM</b>	<b>13</b>
<b>FUELING</b>	<b>15</b>
<b>OPERATION</b>	<b>16</b>
<b>MAINTENANCE</b>	<b>20</b>
<b>ADDITIONAL MAINTENANCE</b>	<b>25</b>
<b>TROUBLESHOOTING</b>	<b>28</b>
<b>REFERENCE</b>	<b>29</b>

THE FOLLOWING SYMBOLS & DEFINITIONS ARE FOUND THROUGHOUT THIS MANUAL AND ARE DESIGNED TO MAKE YOU AWARE OF POTENTIAL HAZARDS OR UNSAFE PRACTICES.

**⚠ WARNING**

A potentially hazardous situation exists which, if not avoided, could result in death or serious injury.

**⚠ CAUTION**

A potentially hazardous situation exists which, if not avoided, may result in moderate or minor injury or property damage.

**IMPORTANT**

A potential situation exists which, if not avoided, may result in product or property damage.

THE FOLLOWING SYMBOLS & LABELS MAY BE FOUND IN THIS MANUAL OR ON THE SAW

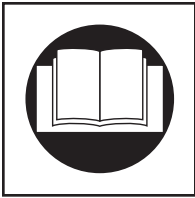

Read the operator's manual carefully and understand the contents before you use this equipment.



Always use:

- Hard hat
- Ear protection
- Protective glasses or full face protection
- Respiratory protection



Wear hand protection



Hazardous dust and gas emissions



**Fire risk due to sparks**



**Reactive forces**



**Maximum spindle speed**

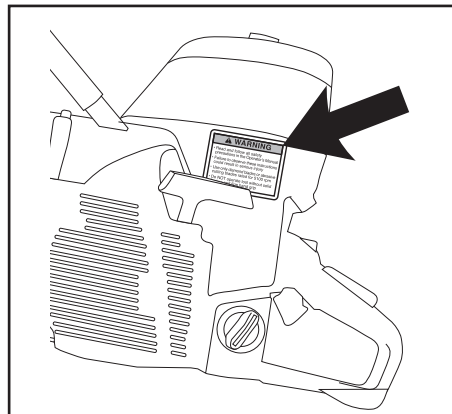
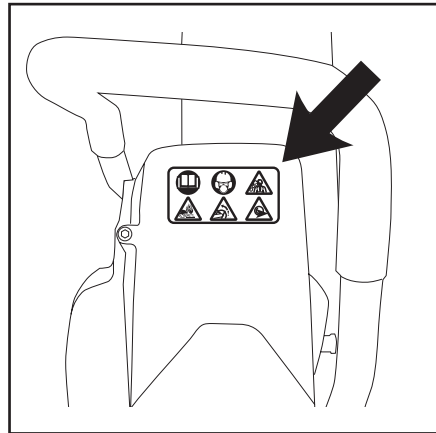
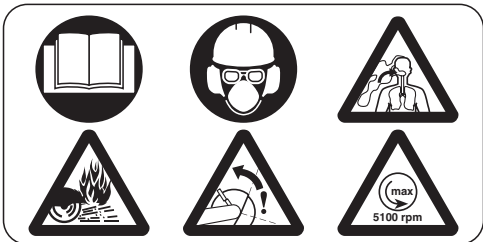

**⚠ WARNING**

- Read and follow all safety precautions in the Operator's Manual
- Failure to observe these instructions could result in serious injury
- Use only diamond blades or abrasive cutting blades rated for 5100 rpm
- Do NOT operate tool without solid footing and firm hand grip

**⚠ WARNING**

**A potentially hazardous situation exists which, if not avoided, could result in death or serious injury.**

**The items listed below are critical to minimizing the risk of injury or equipment damage.**

- DO NOT operate this machine unless you have read and understand this operator's manual.
- DO NOT operate the saw with damaged, modified, broken, or missing guards.
- DO NOT allow blade exposure from the guard to be more than 180 degrees.
- Read all safety materials and instructions that accompany any blade used with this saw.
- Use only abrasive blades or high-speed diamond blades marked for use with gasoline-powered, hand-held, portable, abrasive cutting-off machines.
- DO NOT use abrasive blades that are less than 1/8" (3.17 mm) thick.
- DO NOT use abrasive blades that are not reinforced.
- DO NOT use abrasive blades or diamond blades that are not specifically rated for at least 5100 rpm on 14" (350 mm) or 6200 rpm on 12" (300 mm). Excessive speed could result in blade breakage.
- DO NOT use damaged blades. Always inspect the blade thoroughly.
- DO NOT use an abrasive blade that has been dropped.
- DO NOT use carbide-tipped or toothed type blades of any kind.
- DO NOT grind on the side of a blade.
- DO NOT cock, jam or wedge the blade in the cut.
- Inspect the saw flanges and shafts for damage before installing the blade. DO NOT use if damaged or worn.
- Verify the blade arbor hole matches the machine spindle before mounting the blade.
- Mount the blade solidly and firmly. Wrench tighten the arbor screw.
- Make sure the blade and flanges are clean and free of dirt and debris before mounting the blade on the saw.
- DO NOT insert the blade into a slot narrower than the blade. Rapid pushback may occur.
- DO NOT run the saw upside-down. Debris can fly back into the operator's face.
- Always turn the saw OFF before performing maintenance on the saw.
- DO NOT use equipment that is not functioning properly.
- Turn engine OFF before refueling and allow the engine to cool.
- Keep fuel away from open flame.
- Always provide adequate ventilation when handling fuel.
- Make sure the gas cap on the saw and the fuel can are properly tightened.
- Move the saw at least 10 feet (3 m) away from refueling area before starting.

**⚠ WARNING**

**A potentially hazardous situation exists which, if not avoided, could result in death or serious injury.**

- DO NOT try to stop a moving blade with your hand.
- DO NOT operate this machine when you are tired or fatigued.
- Always wear protective clothing, including hard hat, eye protection, hearing protection, respiratory protection, and gloves.
- Avoid loose fitting clothing.
- Be sure there are no obstructions in the cutting area (plumbing, electrical conduit, air ducts).
- DO NOT operate this machine in an enclosed area unless it is properly ventilated.
- DO NOT operate the machine in the vicinity of anything that is flammable. Sparks could cause a fire or an explosion.
- DO NOT operate the saw while using drugs or alcohol.
- Keep all parts of your body away from the blade and all other moving parts.
- Know how to stop the machine quickly in case of emergency.

**⚠ CAUTION**

**A potentially hazardous situation exists which, if not avoided, may result in minor or moderate injury or property damage.**

- DO NOT touch a dry cutting diamond blade immediately after use. These blades require several minutes to cool after each cut.
- DO NOT leave this machine unattended while the engine is running.
- DO NOT operate a cutting machine if the blade does not stop rotating when the throttle trigger is released.
- Use the correct blade for the type of work being done. Check with blade manufacturer if you do not know if blade is correct.
- Perform safety checks before starting each day.
- DO NOT operate this saw without both hands on the handles. Use a firm grip with thumbs and fingers encircling the handles.
- Keep the handles dry, clean and free of oil or fuel.
- DO NOT operate this saw without solid footing.
- Remove or control slurry to prevent slippery conditions while cutting.
- Set up a well-marked safety zone with a roped boundary and clear signs.
- Always carry the machine with the engine stopped and the muffler away from the body.
- Use caution and follow instructions when setting up or transporting the machine.
- Make sure the blade is not contacting anything before starting the engine.
- DO NOT stand in the blade path while the engine is running.

**IMPORTANT**

A potential situation exists which, if not avoided, may result in product or property damage.

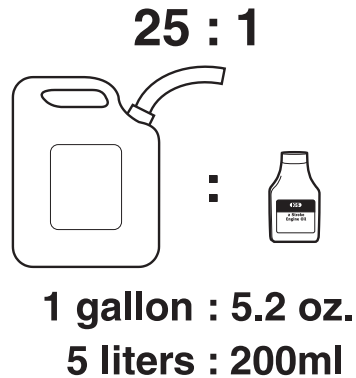
**FUEL**

- Failure to use ICS® brand oil may result in premature engine failure and/or up to 90% reduction in engine life.

NOTE: 1 bottle of ICS® two-stroke engine oil is provided with this saw.

- Always run this saw with a mixture of gasoline and ICS® two-stroke engine oil.
- Always use ICS® brand two-stroke engine oil. If not available, use high-quality oil formulated specifically for air-cooled two-stroke engines.
- Never use two-stroke oil formulated for water-cooled two-cycle engines, such as outboard motor oil.
- Never use motor oil intended for four-stroke engines.
- Use high quality, unleaded gasoline with a minimum octane rating of 90. Lower octane gasoline will cause the engine temperature to increase resulting in piston seizure.
- Always measure the amount of gasoline and oil accurately. Small inaccuracies can drastically affect the ratio of the mixture.

**ENGINE BREAK-IN**

- It is very important to break-in a new engine to “seat” all moving parts, especially the piston rings.
- To break-in the engine, run one full tank of 25:1 fuel at idle, cycling the throttle every 5 to 10 minutes to prevent loading.
- Failure to break-in an engine may result in piston seizure.

**OTHER**

- Clean the machine after each day's use.
- Have the saw repaired by qualified service personnel.
- Always tie down the machine when transporting.



<b>Engine Type</b>	2-stroke single cylinder air cooled
<b>Displacement</b>	3.8 cu-in (64 cc)
<b>Horsepower</b>	4.2 HP (3.1 kW) @ 9,500 rpm
<b>Torque</b>	32 in-lbs (3.6 Nm)
<b>Engine Speed</b>	10,000 +/- 200 rpm 2,400-2,800 rpm idle
<b>Blade Speed</b>	In cut = 4,500 sfm No load = 5,100 sfm
<b>Weight</b>	23 lbs. (10.4 kg) without blade and 26.8 lbs. (12.2 kg) with blade (14 x .110)
<b>Cut Depth</b>	Up to 4.5 inches (11.4 cm)
<b>Dimensions</b>	25 inches (63.5 cm) length 16.125 inches (41 cm) height 8.125 inches (20.6 cm) width
<b>Air Filter</b>	Paper for dry cutting Polyester (optional) for wet cutting
<b>Carburetor</b>	Walbro HDA207, throttle shaft sealed, pressure compensating
<b>Starter</b>	Standard recoil
<b>Ignition</b>	Special water resistant electronic ignition
<b>Clutch</b>	Three-weight, single spring
<b>Fuel ratio</b>	25:1 gasoline-to-oil
<b>Fuel Capacity</b>	24 oz (0.7 Liter) 15-18 minutes run time per tank
<b>Water Supply</b>	Minimum 20 psi (1.5 bar)
<b>Noise Level</b>	101 dB at 3 ft (1 m)
<b>Vibration Level</b>	9.2 m/s <sup>2</sup> (front handle)
<b>Engine Break-in Period</b>	One tank, without cutting, cycling throttle
<b>Spark Plug</b>	Champion CJ7Y, Bosch BWS7F, or NGK BPMR7A

ASSEMBLING THE SAW

**1**

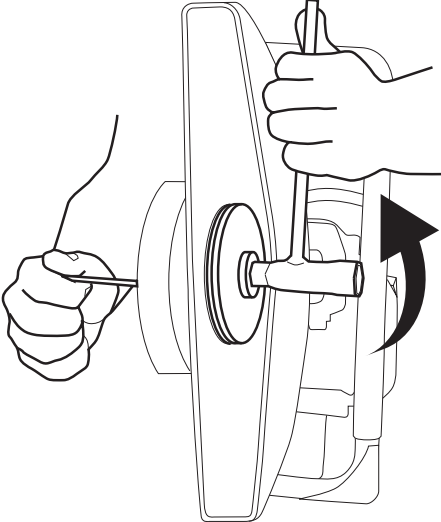

- Insert flange stop tool in the belt cover, rotate blade flanges until tool engages belt pulley.

**2**

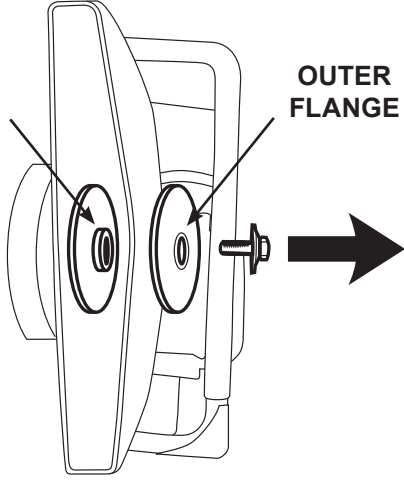

- Loosen the flange bolt and remove bolt and blade flanges.
- Check blade arbor hole diameter.

**3**

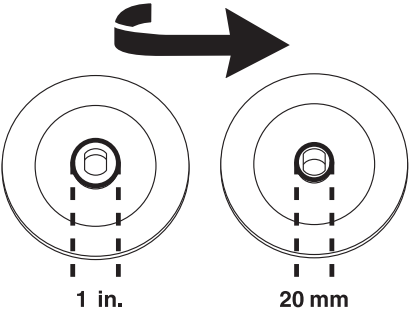

- Choose appropriate side of the inner flange to use for your blade.
- NOTE: One side of the inner flange is 1 inch (25.4 mm) the other is 20 mm.

**4**

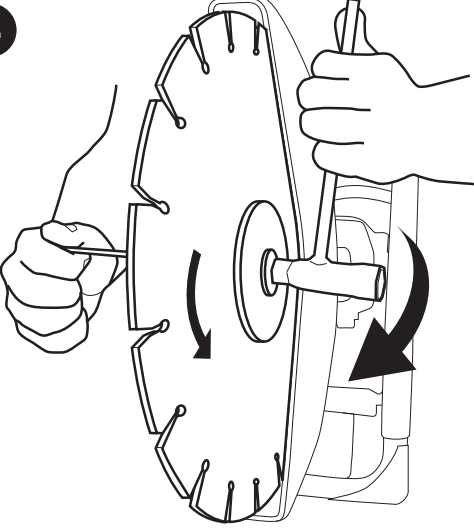

- Place inner flange on the drive shaft.
- Mount blade in proper direction of rotation.
- Insert flange stop tool in the belt cover and tighten flange bolt 18.4 ft-lbs (2.5 Nm).

## WATER KIT INSTALLATION

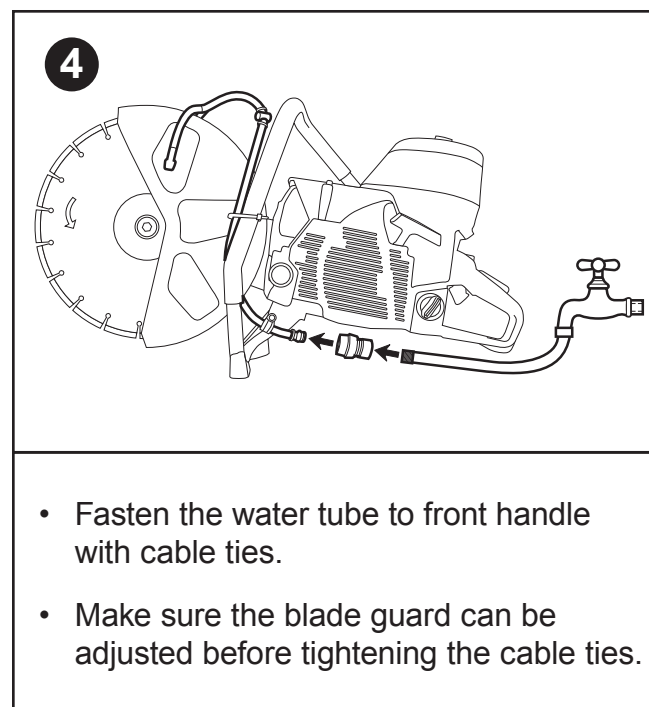
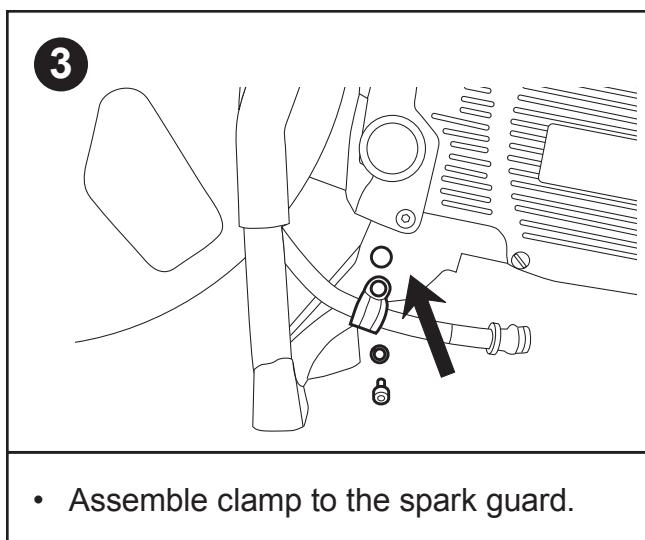
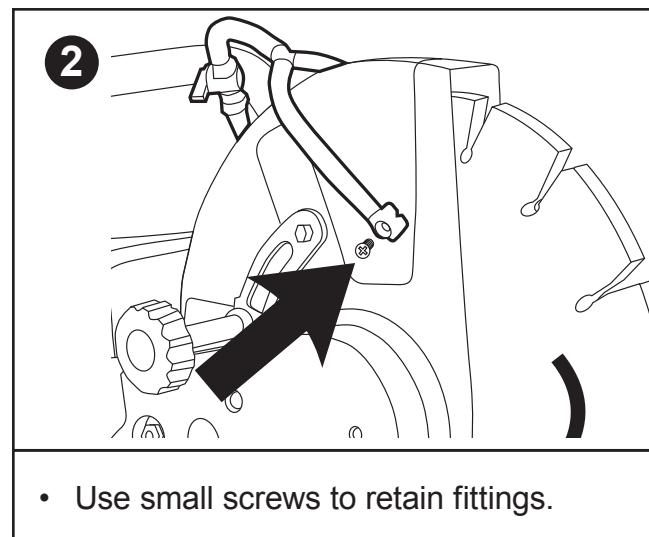
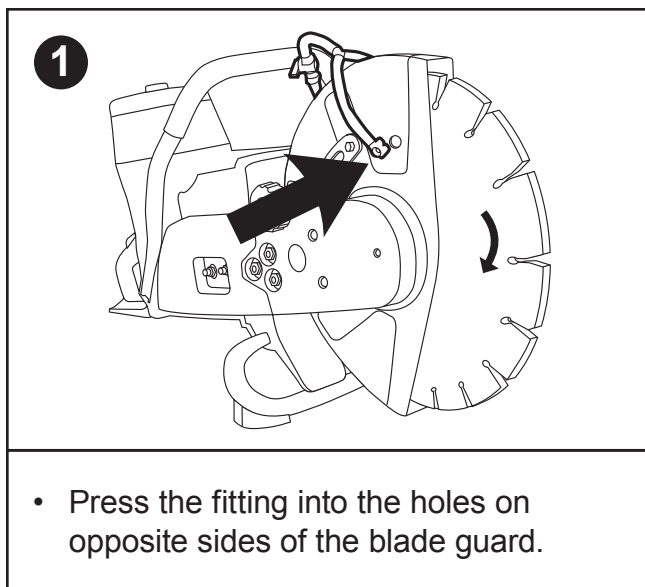

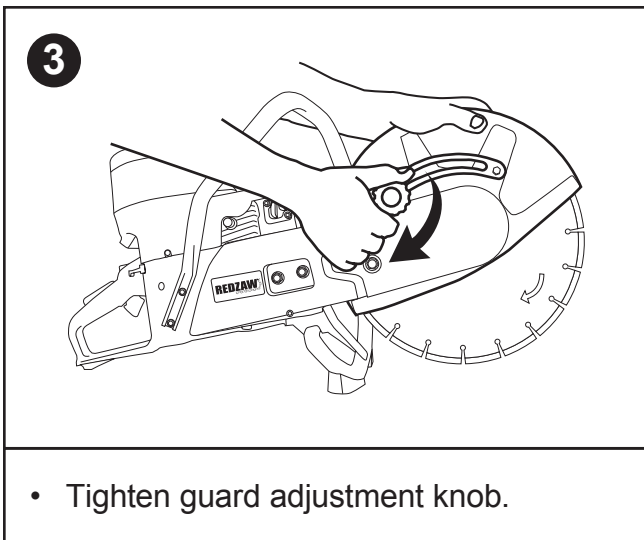
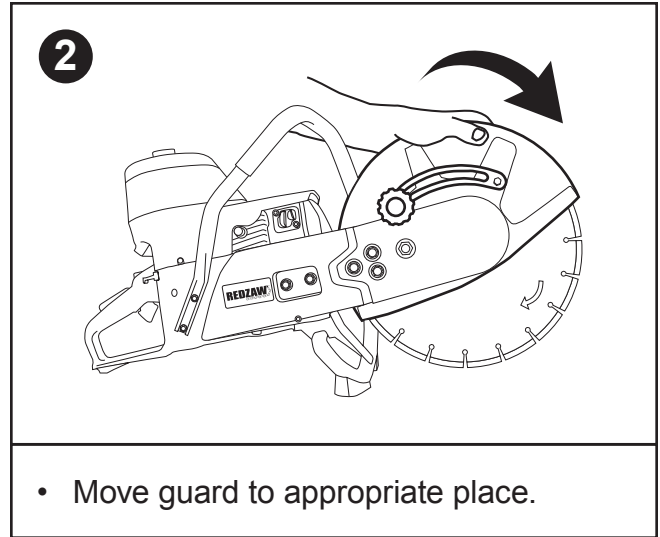
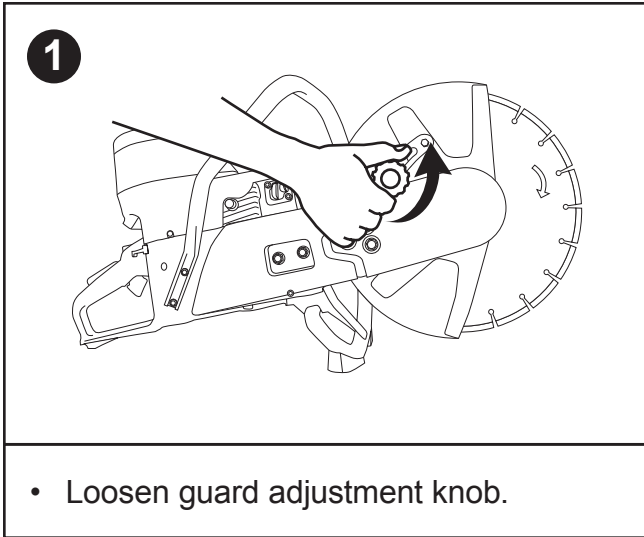

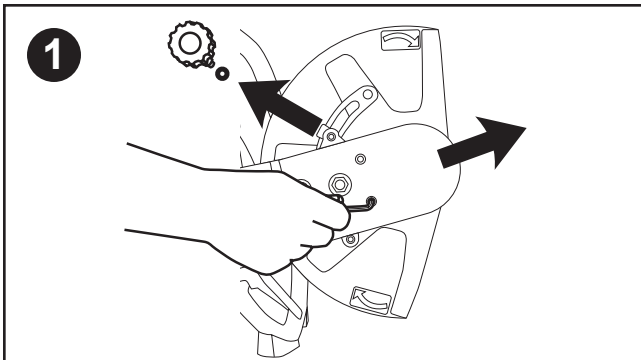

- Remove guard adjustment knob and wave washer.
- Remove belt cover screws and belt cover.

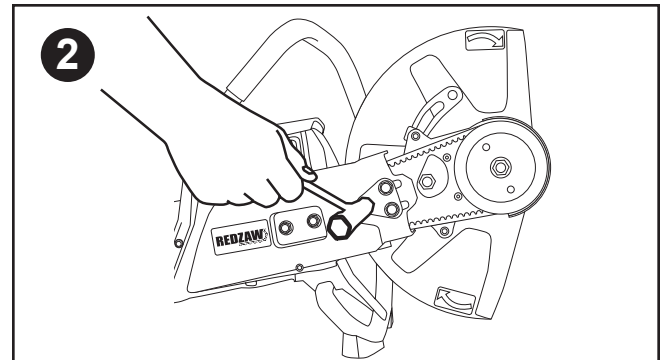

- Remove three blade arm nuts.
- Remove the three hole triangular plate.

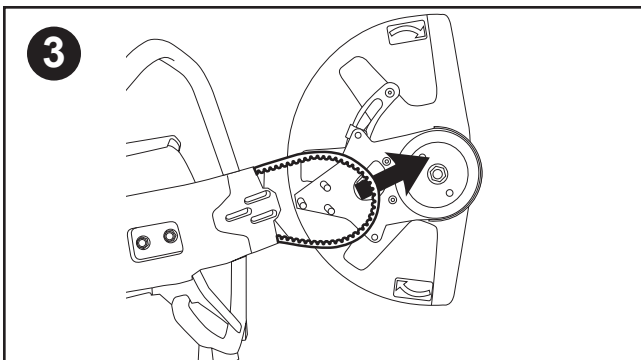

- Remove the belt from pulley and blade arm.

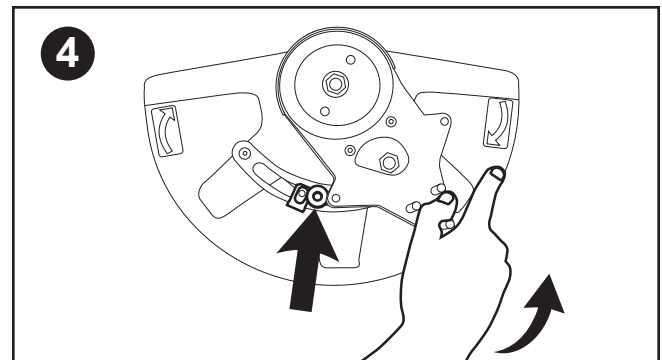

- Rotate blade arm to the right and remove spacer.

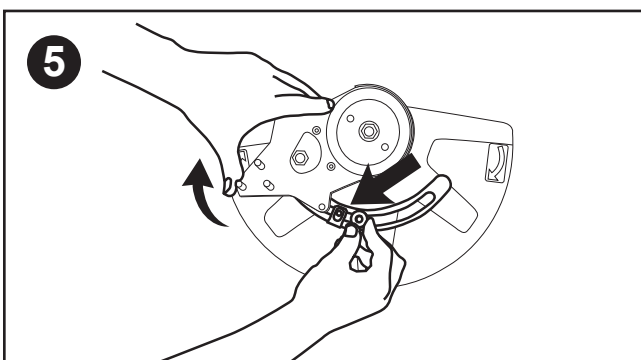

- Rotate blade arm left and align spacer over nut clip.
- Make sure arm hole, spacer and nut clip are aligned.

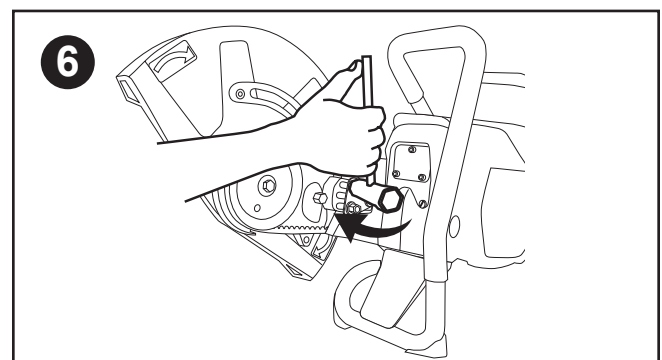

- Replace blade arm on reverse side and pull belt onto pulley.
- Replace triangular plate and nuts.

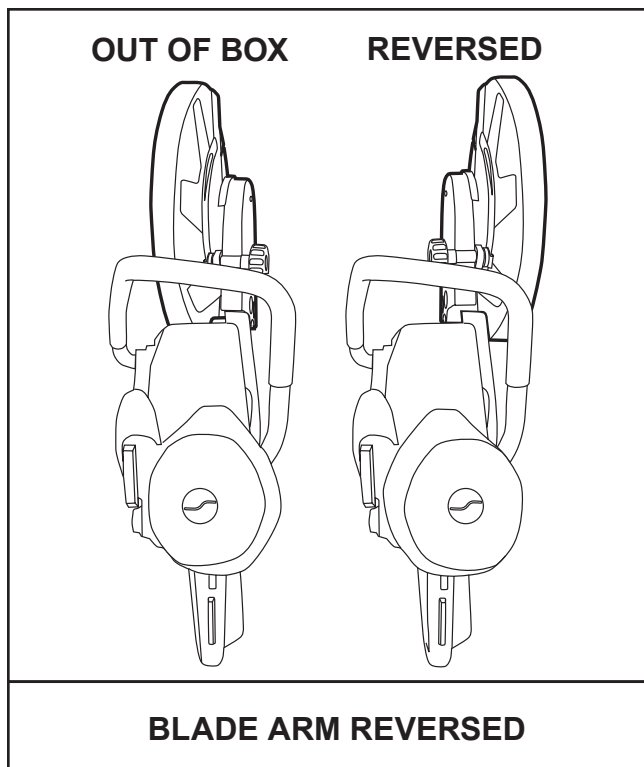
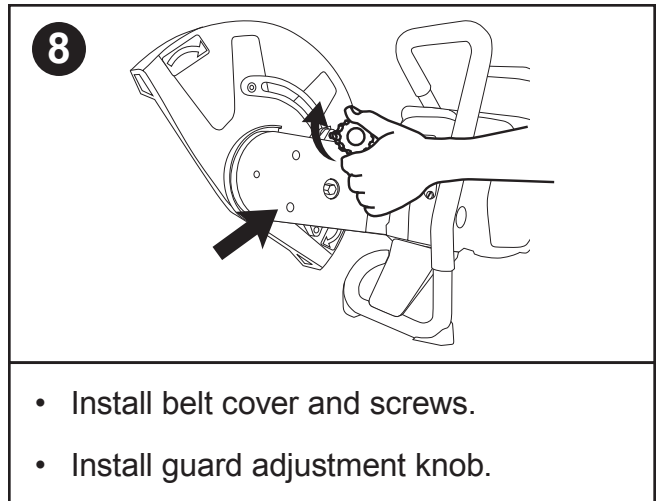
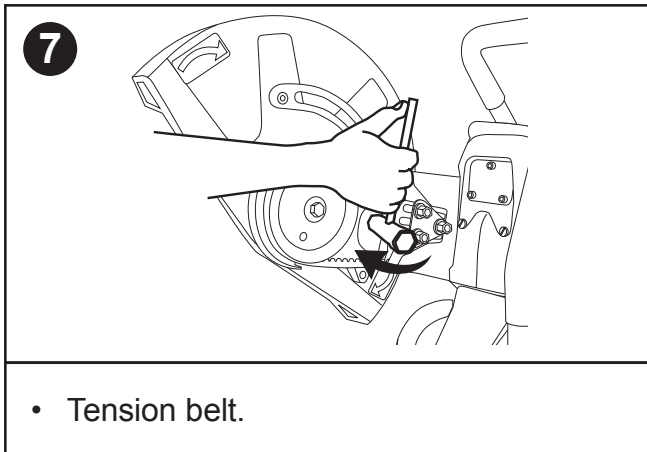

## FUEL HANDLING

**CAUTION**

Always run this saw with a mixture of gasoline and ICS® two-stroke engine oil.

**25 : 1**

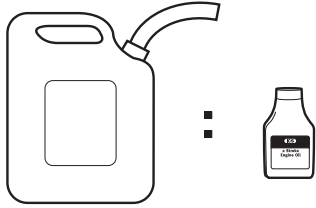

**1 gallon : 5.2 oz.**  
**5 liters : 200ml**

GASOLINE	OIL
US Gallon	US Fl oz
1	5.2
2 1/2	12.8
5	25.6

GASOLINE	OIL
Liters	ml
1	40
5	200
10	400
20	800

- Use premium unleaded gasoline with a minimum octane rating of 90. If lower octane gasoline is used, engine temperature will increase which can result in a piston seizure and damage to the engine.
- Always provide adequate ventilation when handling fuel.
- Use caution when handling gasoline. Avoid direct contact with skin or inhaling fuel vapor.

## FUEL MIXING

- Always mix gasoline and oil in a clean container intended for use with fuel.
- Keep fuel container closed tightly to prevent moisture from getting into the fuel.
- Always begin mixing fuel by adding half the amount of gasoline to be used. Then add the correct amount of two-stroke oil for 25:1 mixture and finish filling the container with gasoline.
- Do not mix more than one month's supply of fuel. This helps prevent the separation of the two-stroke oil from the gasoline (varnishing).
- If the saw is not used for an extended period of time (3 months) the fuel tank should be emptied and cleaned.

## FUELING

- Always shut off the saw before fueling.
- Before fueling, clean the area around fuel cap to prevent dirt from contaminating the fuel. Contamination of the fuel tank can lead to saw malfunction.
- Thoroughly mix the fuel in it's container before fueling.
- Slowly open the fuel cap to release any pressure that may have built-up in the tank.
- After adding fuel, tighten the fuel cap carefully and secure with a wrench.

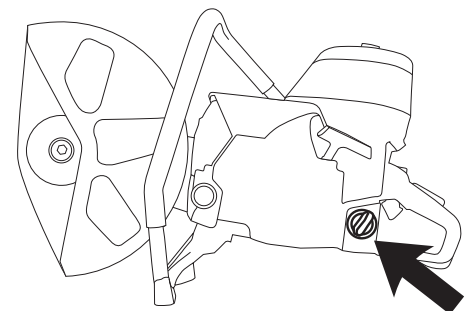

Fuel Cap

## STARTING AND STOPPING THE SAW

**CAUTION**

Always move the saw at least 10 feet (3 m) away from the fueling area before starting.

**IMPORTANT**

Place the saw on clear ground. Ensure that secure footing is established and blade is not contacting any objects.

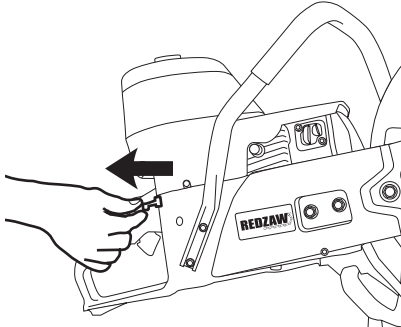
**1**

- Pull the choke lever out.

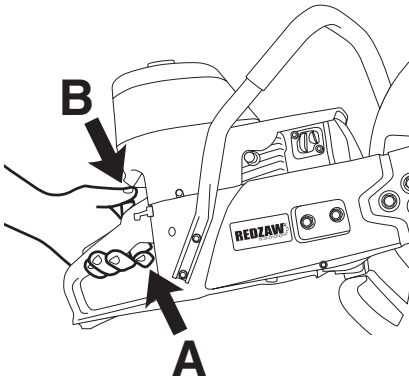
**2**

- Lock the throttle in the start position by depressing and holding the throttle lock button while releasing the trigger (A) and trigger interlock (B) in succession.

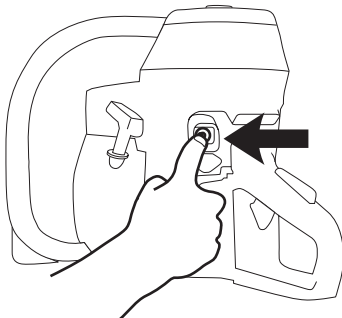
**3**

- Toggle the ignition switch to "ON".



4

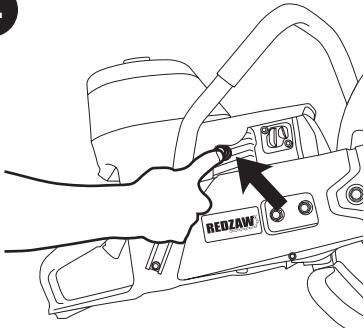

- Press decompression valve on subsequent start ups.

5

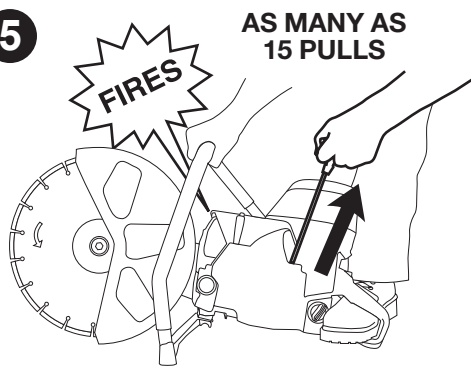

- Place the saw on the ground making sure the blade is free of any obstructions.
- Place right foot on the base of the rear handle.
- Place left hand on the front handle.
- With right hand, slowly pull starter handle until the starter pawls engage.
- Pull the starter rope (*hard, fast, short pulls*) until engine fires – could be as many as 15 pulls on very first start-up of saw.

6

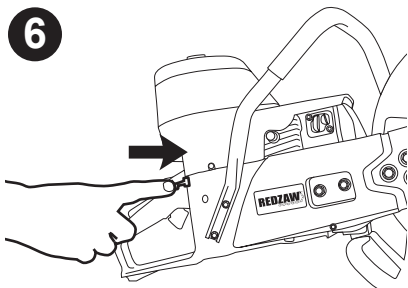

- After the engine fires it will be necessary to push the choke lever in.
- Push the decompression valve in.

7

5 TO 7 PULLS

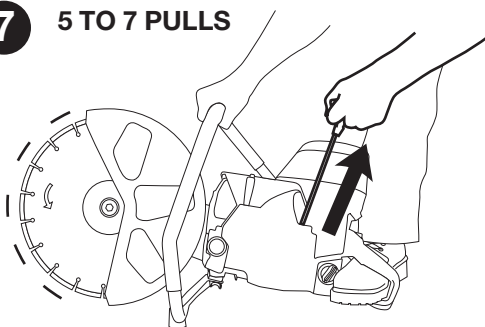

- Pull the starter rope until engine starts – could be as many as 5 to 7 pulls.
- When the engine starts, release throttle from starting position.
- Allow engine to idle for at least one minute; squeeze throttle trigger several times during this period.

## WARM ENGINE STARTING PROCEDURE

Use the same procedure as starting cold engine, but **DO NOT pull choke lever out**. If choke is used, the carburetor will flood with gas.

If the engine does not start in 3 hard, fast pulls with the throttle locked, unlock the throttle and pull the starter cord 3 more times.

## PRE-CUT CHECKLIST

- Ensure proper belt tension.
- Ensure the blade is mounted correctly.
- Ensure all safety devices are properly mounted and functional and that all controls are in proper working order.
- Be sure there are no obstructions (plumbing, electrical conduit, air ducts).
- Always wear protective clothing, including hard hat, eye protection, hearing protection, non-slip safety boots, gloves, and avoid wearing loose fitting clothing.

## PLANNING THE CUT

- Outline the cut with a permanent marker for a visual cutting guide.
- Avoid pinching the blade. Always cut the bottom of an opening first, then top, and then the sides. Save the easiest cut for last.
- For the straightest cuts use the “Step Cut” method. First score the entire cut line approximately a half-inch deep. Next, deepen the cut by about two inches. Then complete the cut.
- Be sure cut concrete cannot fall and injure operator or bystanders. Concrete is very heavy, one cubic foot = 12” x 12” x 12” = 150 lbs. (30 cm x 30 cm x 30 cm = 68 kg).

## CUTTING WITH THE RZ60C CHOP SAW

To start a cut, hold trigger on full throttle and slowly plunge the blade straight into the wall.





### CUTTING TIPS

- Always operate the saw at full throttle. Apply enough feed force so that the free running RPM drops 20 to 30%. If too much force is applied, the saw will lug or stall. The blade will not have enough speed to cut effectively. If too little feed force is applied, the diamonds will skid and glaze over.
- For straighter cuts use the “step cut” method. First score the entire cut line with the blade approximately 1/2 inch (12 mm) to 1 inch (25 mm) deep. Next, deepen the cut by about 2 inches (50 mm). This groove will help guide the blade for a straight cut. Then complete the cut.
- Plunge cut instead of starting at the top of the wall. This will reduce chatter, extend blade life, create a straighter cut.
- When cutting heavy rebar, move the blade in and out of the steel so that the blade is always cutting concrete as well as steel. This will help keep the diamonds exposed. Also, expect less diamond blade life when cutting heavy rebar.

**Follow these simple maintenance guidelines  
and your RZ60C Chop Saw will keep running at its very best.**

**AFTER EACH USE**

Follow the directions on the Daily Maintenance Label, located on the air filter cover.

<b>DAILY MAINTENANCE</b>	
<p><b>CLEAN</b></p> 	<p>• Clean &amp; oil primary air filter</p> 
<p><b>INSPECT</b></p> 	<p>• Secondary air filter</p> 
<p><b>INSPECT</b></p> 	<p>• Blade wear • Blade damage • Blade rotation direction • Arbor flanges • Arbor flange bolt torque</p>

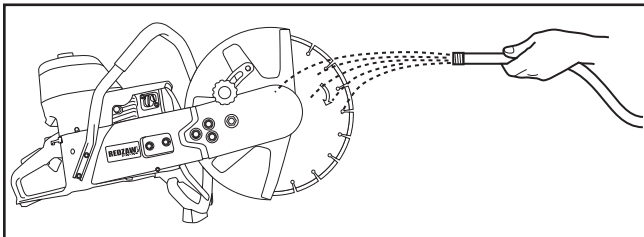

- Clean the saw with water if cutting wet and wipe off.

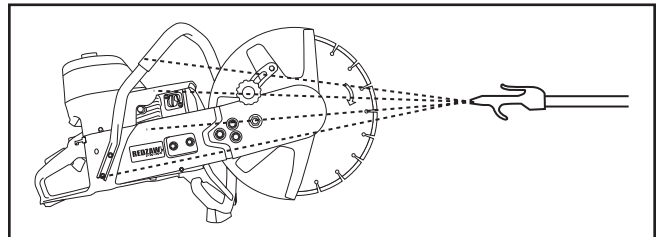

- Blow off the saw with air if cutting dry.

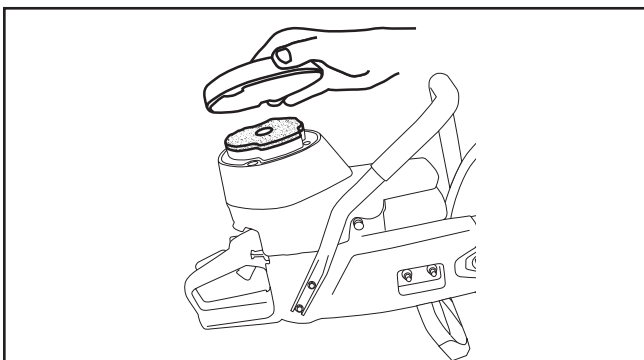

- Remove the cover and prefilter.
- Clean by shaking pre-filter vigorously.
- Do not use compressed air.
- Wash pre-filter with warm soapy water.
- Dry thoroughly.
- Re-oil with foam filter oil.

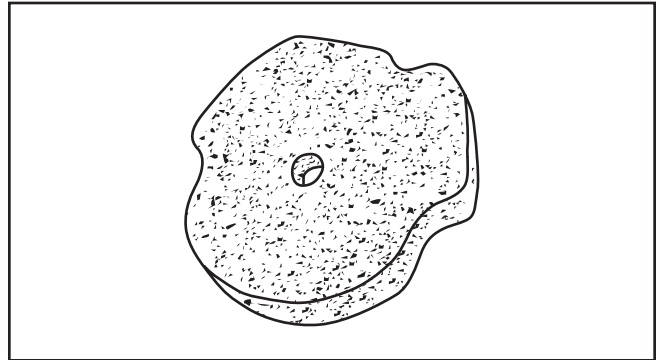

**NOTE:** It is recommended to keep spare pre-filters on hand. Regular exchange will prolong the life of the primary air filter.

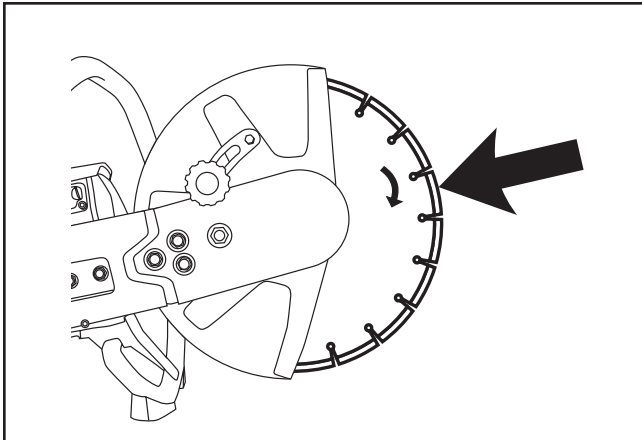

- Inspect blade for excessive, uneven, or irregular wear.
- Inspect blade for damage – cracks, missing segments, not flat, arbor hole damage, blueing, or undercut segments.
- Ensure the rotation direction is correct.

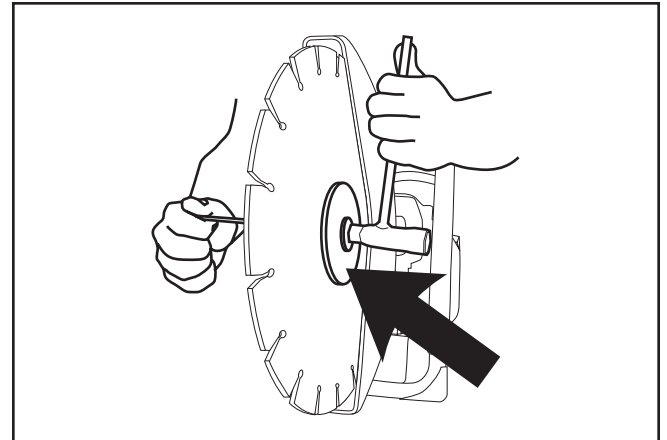

- Inspect the arbor flanges for damage.
- Ensure that the arbor flange bolt is adequately tightened 18.4 ft-lbs (2.5 Nm).

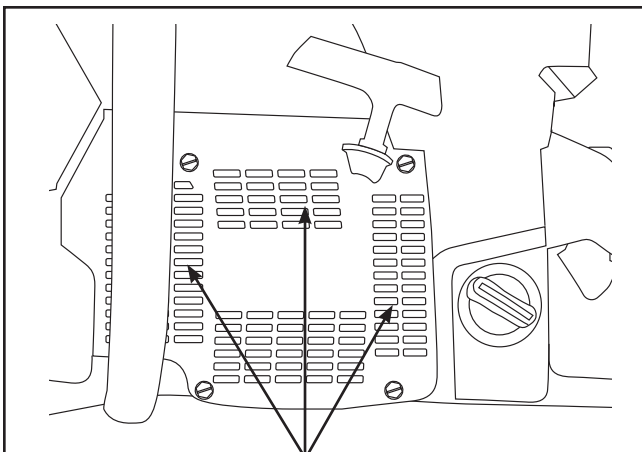

- Thoroughly flush the starter housing assembly with water.
- Lubricate the starter pawls by spraying light weight oil into the starter housing through the vents.
- Check the starter cord for fraying, replace if necessary.

BELT TENSION

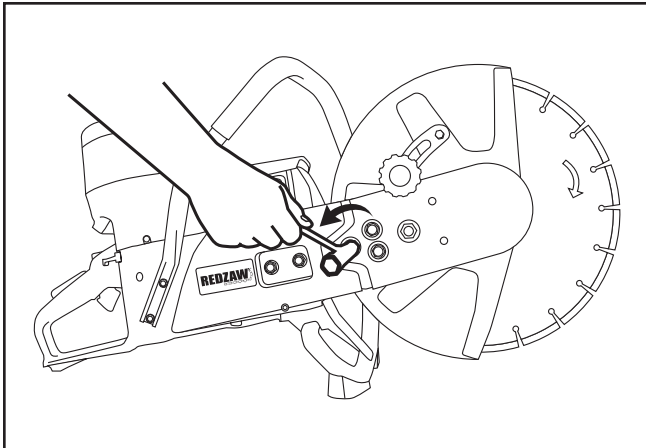

- Loosen three side cover fasteners.

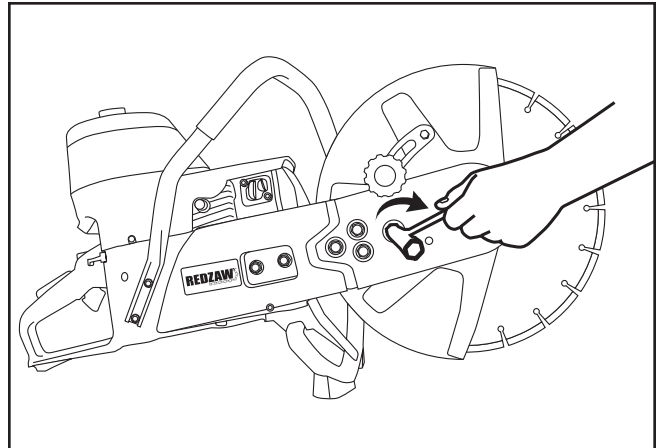

- Turn belt tensioner clockwise to tighten.

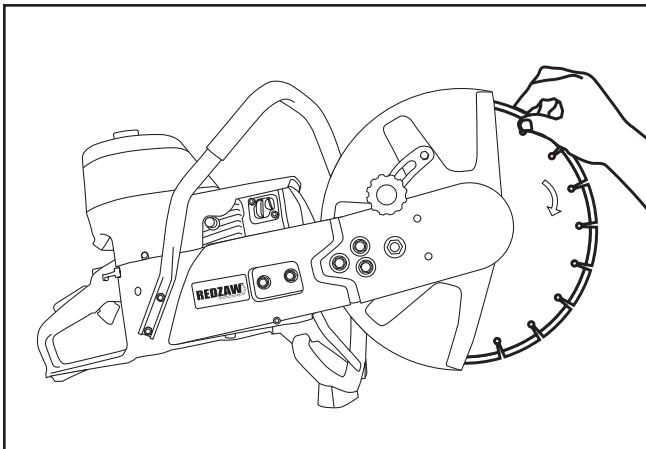

- Check belt tension by rotating blade.
- Blade should rotate with moderate resistance.

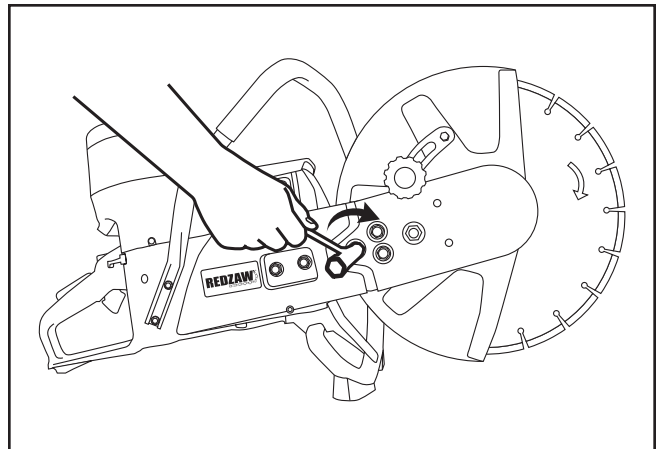

- Tighten side cover fasteners.

## AFTER 10 HOURS OF USE

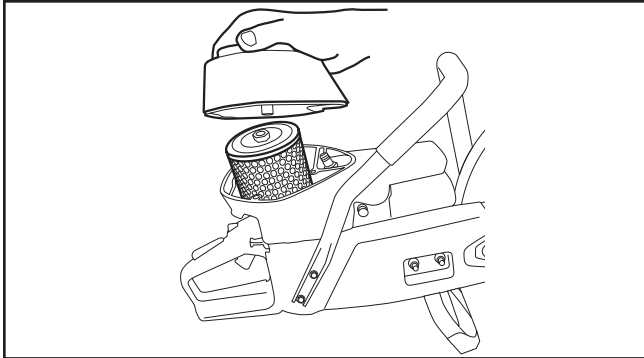

- Remove the primary air filter cover.

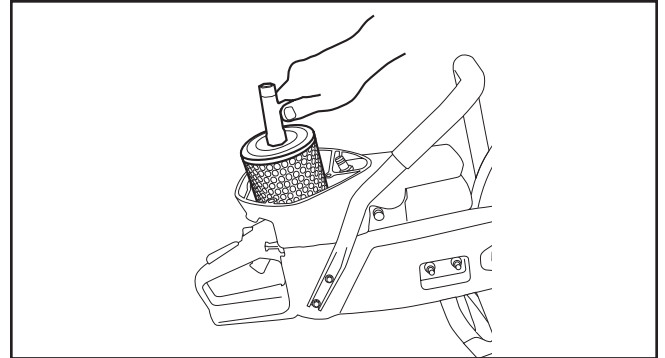

- Remove the primary air filter and internal screen.

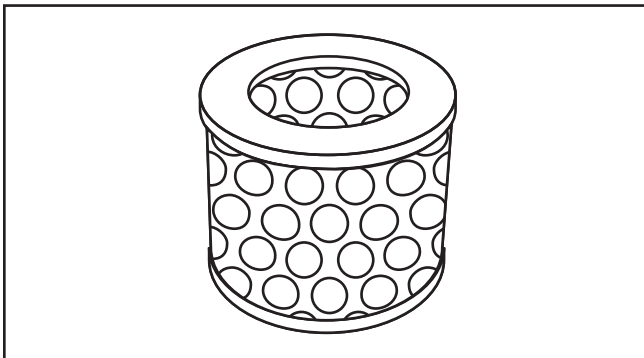

- Clean primary filter by shaking vigorously and dusting off with a soft brush.
- Do not use compressed air.

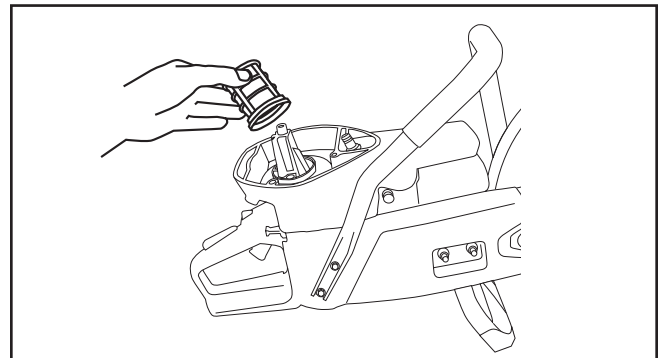

- Clean internal screen by shaking vigorously and dusting off with a soft brush.
- Do not use compressed air.

**AFTER 20 HOURS OF USE**

- Repeat air filter cleaning. See 10-hour use maintenance section.

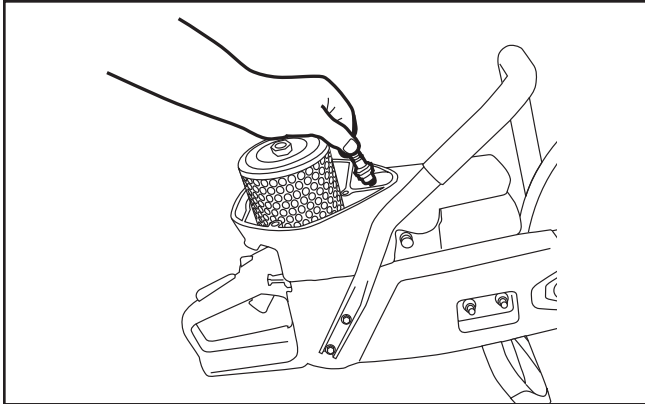

- Remove spark plug and clean with a wire brush.

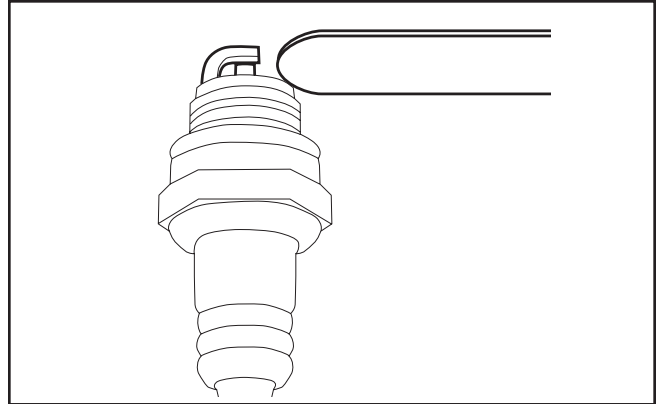

- Check the electrode gap.
- The correct gap is 0.020 inches (0.5 mm).

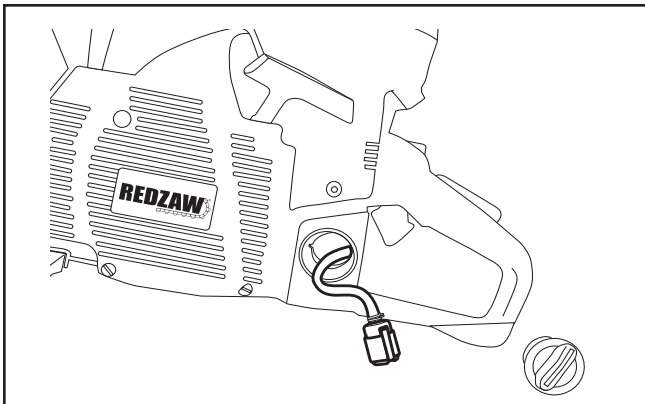

- Replace fuel filter.

**AFTER 40 HOURS USE**

- Replace pre-filter.
- Replace primary filter.
- Replace internal screen.
- Replace spark plug.
- See 10- and 20-hour use maintenance sections.



## STARTER HOUSING ASSEMBLY

**IMPORTANT**

It is common for concrete slurry to get inside the starter housing assembly during cutting. This can cause the starter pawls to stick and not engage when the rope is pulled.

- After each usage, thoroughly flush the starter housing assembly with water. (Figure 1)
- Lubricate the starter pawls by spraying light weight oil into the starter housing through the vents. (Figure 1)
- Check the starter cord for fraying, replace if necessary.

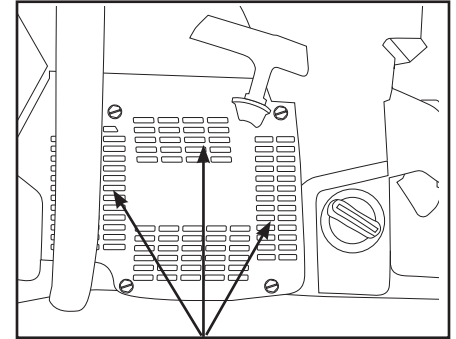

Figure 1

## STARTER CORD REPLACEMENT

- Remove the 4 screws that attach the starter assembly to the crankcase.
- Pull the cord out approximately 8" and lift the cord up into the notch in the pulley (Figure 2). Relax the recoil spring by placing thumb on pulley and gently allow the pulley to unwind entirely. Undo the screw in the center of the pulley and remove the pulley.
- Thread the new cord through the starter cover and fasten it to the pulley. Wind 4 turns of the starter cord on to the pulley. Assemble the starter pulley against the recoil spring so the end of the spring engages into the backside of the pulley. Install the retaining screw in the center of the pulley.

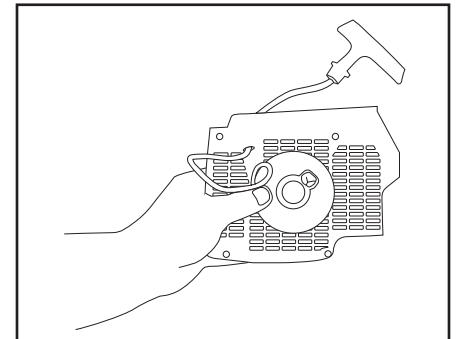

Figure 2

## TENSIONING THE RECOIL SPRING

- Lift the starter cord up into the notch on the starter pulley (Figure 3) and wind the pulley clockwise 5 full turns. Remove the cord from the pulley notch while pinching the pulley. Release the pulley slowly allowing it to wind the rope counterclockwise onto the pulley.
- When completed, the starter handle should be pulled back in the starter housing under its own tension.
- To check that the starter pulley was assembled correctly, pull the cord completely out of the housing, grip the pulley and turn clockwise another 1/2 turn. If the pulley turns another 1/2 turn it is correctly assembled.

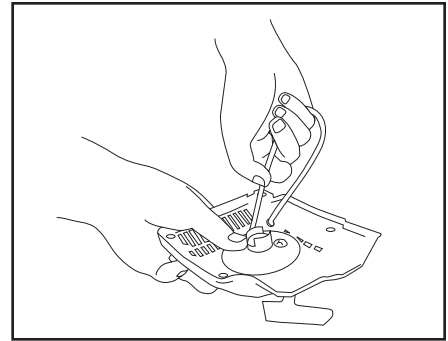

Figure 3

## STARTER HOUSING ASSEMBLY

- To reattach the starter housing, first pull the starter cord out, then hold the starter housing against the crankcase (Figure 4). Slowly release the starter cord to enable the pulley to fit between the pawls.
- Insert and tighten the screws. Use blue Loctite® #242.

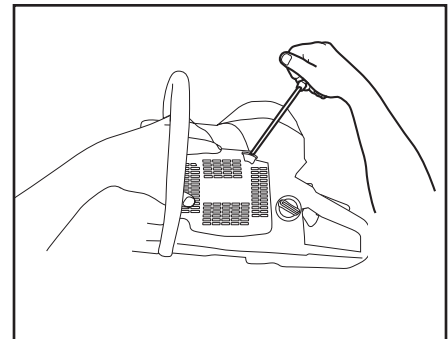

Figure 4

## SPARK PLUG

- A worn or fouled spark plug can cause a loss of power, difficulty starting or rough idle (Figure 5).
- If the spark plug is dirty, clean it with a wire brush and check the electrode gap. Readjust if necessary. The correct gap is .020" (0.50 mm).
- The spark plug should be replaced after 40 hours of operation or earlier if the electrode is badly corroded.
- Always use the recommended spark plug type. Using the wrong spark plug can severely damage the piston and cylinder (see page 9 for part #).

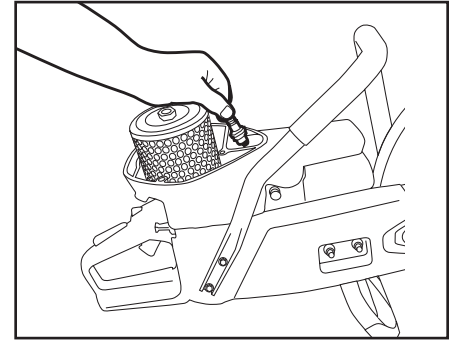

Figure 5

## CARBURETOR

- The function of the carburetor is to mix fuel with air. Adjustments other than idle speed should be made by a servicing dealer.
- **Before adjusting the engine idle speed, make sure the air filter is clean and the engine is warmed up.**

**T – Idle Screw** is adjusted so that the engine idles smoothly but the clutch does not engage (Figure 6).

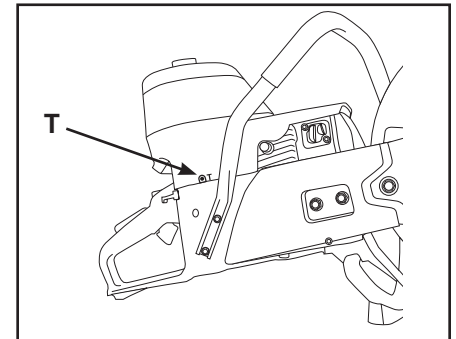

Figure 6

- **If saw has been running satisfactorily and there is a gradual decrease in power and drop in RPM at full throttle, the filter may have become dirty or saturated with water.**

**TROUBLESHOOTING**

- **CHOP SAW WON'T REACH FULL RPM** – Air filter or pre filter may be dirty.
- **WATER NOT FLOWING** – Water hose is kinked or supply is not turned on.
- **WON'T START** – Turn ignition switch on or possible defective spark plug.
- **WON'T START** – Low compression, less than 120 psi (8 bar). Possible incorrect fuel mixture.  
Reference: new = 150 to 180 psi (10 to 12 bar)  
used = 140 to 160 psi (9 to 11 bar)
- **DIFFICULT TO START** – Possible flooded engine. Turn ignition switch on, push choke in, hold throttle on full with foot and pull starter cord until engine starts.
- **DIFFICULT TO START** – Possible fouled spark plug. Remove spark plug, clean with wire brush and re-gap.

**Further questions?  
Call 1-800-321-1240**

## APPROXIMATE CUTTING RATES

Material	Cutting Rate
Hard aggregate & steel	25 - 35 in <sup>2</sup> /min (160 - 225 cm <sup>2</sup> /min)
Medium aggregates	30 - 40 in <sup>2</sup> /min (190 - 260 cm <sup>2</sup> /min)
Masonry, soft aggregates	40 - 60 in <sup>2</sup> /min (260 - 390 cm <sup>2</sup> /min)

## INCH-FOOT DEFINITION

An in-ft is a measure of how much material is to be cut.

An in-ft is defined as: depth in inches times length in feet.

Note: 129 in-ft = 1m<sup>2</sup>

Example: How many in-ft are in this doorway?

1. Determine the depth of the cut in inches.  
For this example, 8 inches.
2. Determine the length of the cut in feet.  
 $3+7+3+7=20$  feet
3. Multiply the two numbers  
 $8 \text{ in} \times 20 \text{ ft} = 160 \text{ in-ft}$

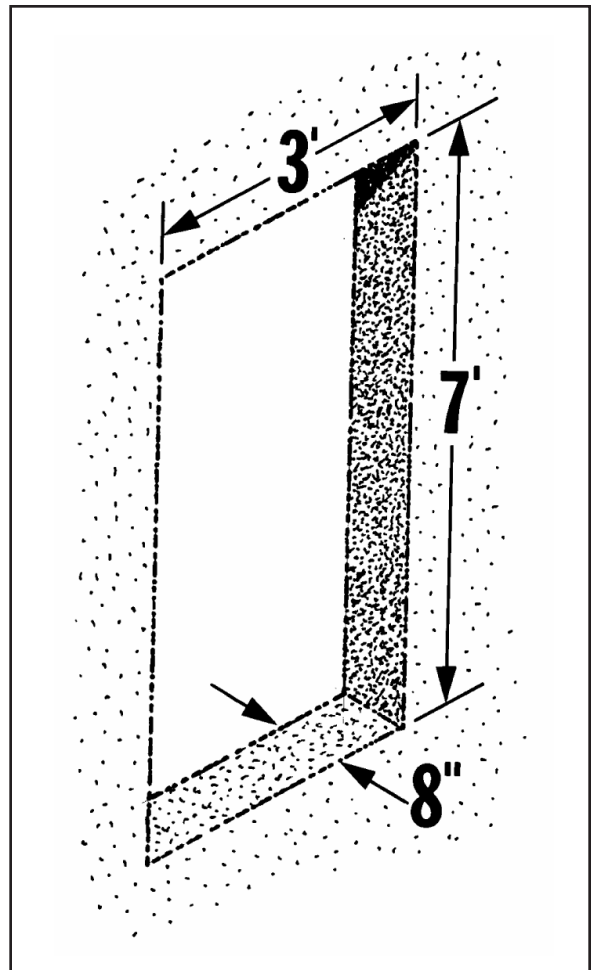





# ICS® RZ60C OPERATOR'S MANUAL

**ICS, Oregon Tool Inc.  
4909 SE International Way  
Portland, OR 97222  
Tel 800-321-1240  
icsdiamondtools.com**