

MERIT

AN ICS BRAND



M250-30H - HYDRAULIC POWER

PRODUCT DATASHEET

MERIT

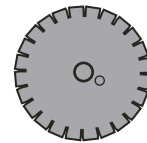
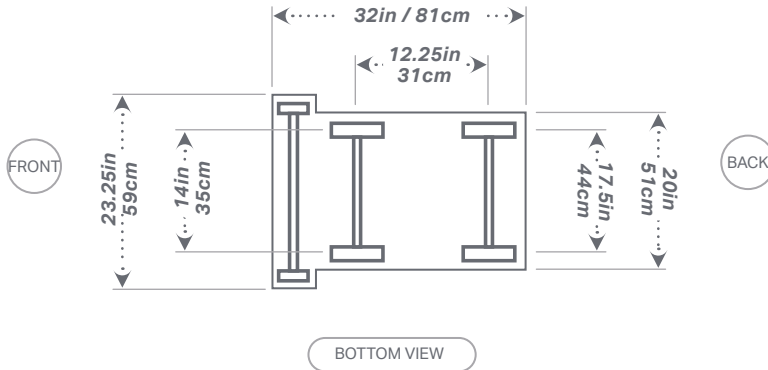
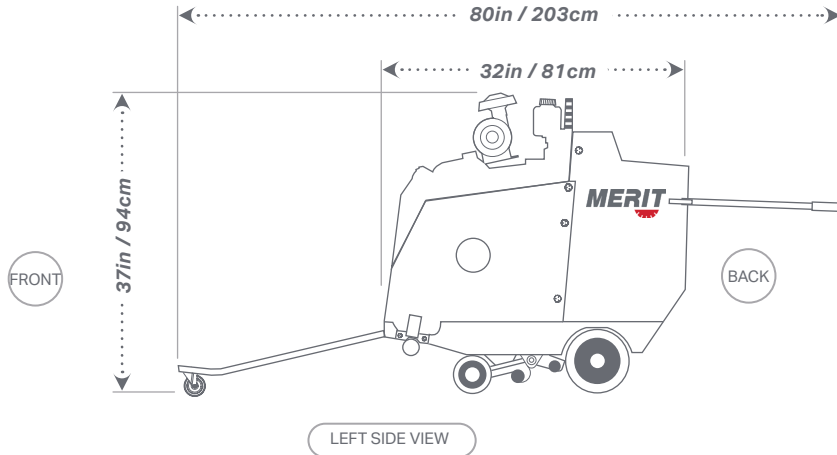

14in- 24in
35cm - 61cm

10in/25cm Max Cut



SPECIFICATIONS

Raise & Lower Control	Manual
Air Filter	N/A
Blade Mounting	Left and right
Blade Shaft Drive	1in / 2.5cm with 4in / 10cm arbors
Approx. Weight	480lbs. / 218kg.
Drive Speed	0-200 FPM
Depth Control	Manual
Spindle Size	1.25in / 3cm with tapered roller bearings
Arbor Size	1in / 2.5cm
Engine Manufacturer	Cross
Fuel Capacity	N/A
Hydraulic Flow	28gpm / 106lpm
PSI	2500psi / 172bar

BLADE GUARD IN	BLADE GUARD CM
14 x 2	35.5 x 5
18 x 2	46 x 5
20 x 2	50 x 5
24 x 2	61 x 5

Part Number	Description
M250-30H-SP	M250, 30HP, HYDRAULIC, SELF-PROPELLED FLAT SAW



Diamond Tools and Equipment

ICSDIAMONDTOOLS.COM | 800.321.1240

Effective January 1, 2024 | Copyright 2024 ICS, Oregon Tool Inc. Pricing, product offerings and specifications are subject to change without notice. All rights reserved. WallWalker, SpeedHook, SealPRO, FORCE4, FORCE3 and PowerGrit are registered trademarks of ICS. The best way to cut concrete, DCT, TSS, and ProFORCE are trademarks of ICS. Rev: 010124