

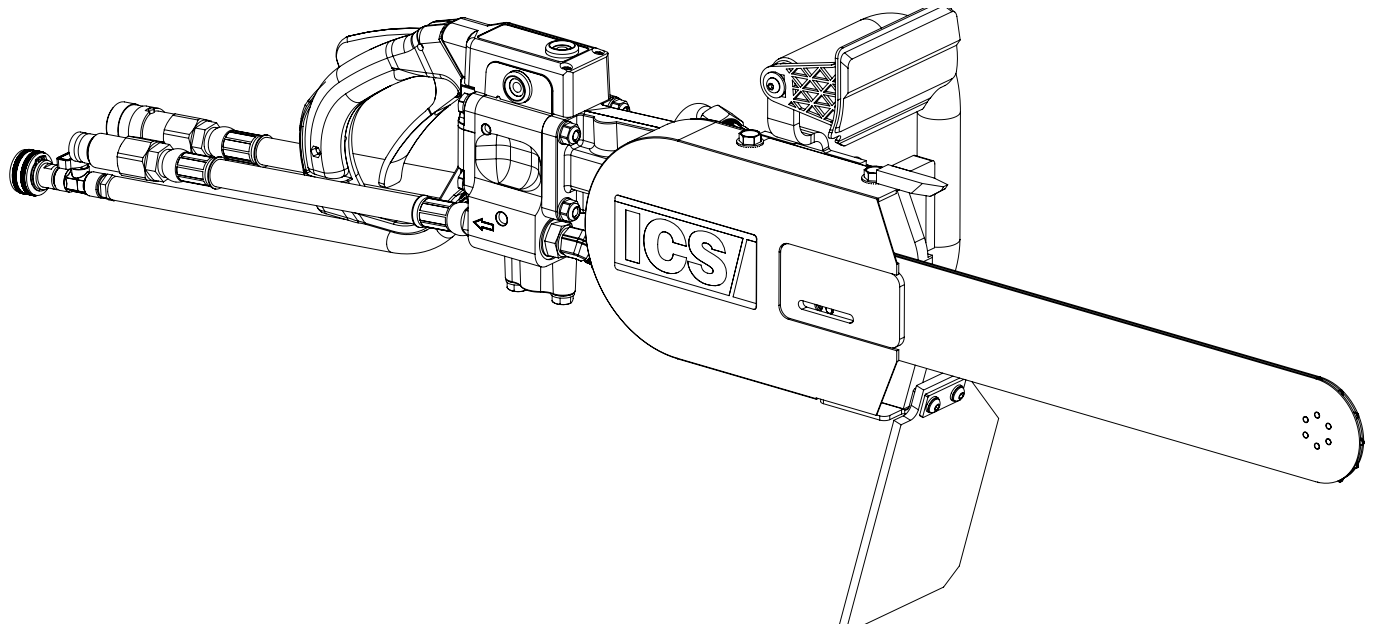

890F4 FLUSH

Flush Cut Hydraulic Saw



OPERATOR'S MANUAL

INTRODUCTION

This manual outlines the maintenance and operation of ICS® manufactured products.

This is a professional tool and is solely intended for use by trained and experienced operators.

The 890 FLUSH chainsaw is designed to cut concrete, stone and masonry when used with the appropriate ICS Diamond Chain. Ductile iron pipe may be cut ONLY if using PowerGrit® Utility Saw Chain.

To get the maximum benefit from your saw, and ensure maximum safety, be sure to read this manual thoroughly and periodically review safety instructions.

TABLE OF CONTENTS

SYMBOLS & LABELS	4
SAFETY	5
TECHNICAL SPECIFICATIONS	7
SET-UP	8
OPERATION	11
MAINTENANCE	14
TROUBLESHOOTING	15
REFERENCE	16
DECLARATION OF CONFORMITY	18

THE FOLLOWING SYMBOLS AND DEFINITIONS ARE FOUND THROUGHOUT THIS MANUAL AND ARE DESIGNED TO MAKE YOU AWARE OF POTENTIAL HAZARDS OR UNSAFE PRACTICES.

 **WARNING**

A potentially hazardous situation exists which, if not avoided, could result in death or serious injury.

 **CAUTION**

A potentially hazardous situation exists which, if not avoided, may result in minor or moderate injury or property damage.

IMPORTANT

A potential situation exists which, if not avoided, may result in product or property damage.

THE FOLLOWING SYMBOLS & LABELS MAY BE FOUND IN THIS MANUAL OR ON THE SAW



Read the operator's manual carefully and understand the contents before you use this equipment.









Always use:

- Protective helmet
- Ear protection
- Protective glasses or full face protection



Wear hand protection

 **WARNING**

-  • Do not exceed 8gpm (30 lpm) hydraulic flow or 2500 psi (172.5 bar) hydraulic pressure.
-  • Do NOT insert tool into slot narrower than chain.
-  • Do NOT run the saw backwards. The chain should travel away from the operator on the top of the bar and return on the bottom of the bar.
-  • Do NOT operate tool without solid footing and firm hand grip.
-  • Failure to observe these precautions can result in serious injury
-  • Fluids escaping under pressure can penetrate the skin.

 **WARNING**

- Do NOT operate saw without side cover.
- Do NOT use this saw cover on any other saw model.
- Do NOT operate saw without baffle drain.
- Failure to observe these precautions can result in serious injury.

THE FOLLOWING SYMBOL APPLIES TO ALL THE ITEMS LISTED ON THIS PAGE

 **WARNING**

A potentially hazardous situation exists which, if not avoided, could result in death or serious injury.

Diamond chain breakage can result in high-speed ejection of parts, which can result in death or serious personal injury to operators or bystanders. The items listed below are critical to minimizing the risk of diamond chain breakage and injury.

- **DO NOT** operate a diamond chain saw with a damaged, modified, broken or missing side cover, bottom guard or guard flap. The side cover, bottom guard and guard flap provide protection against contact with moving parts, ejected debris, broken diamond chain, thrown water and concrete slurry.
- **DO NOT** operate saw with loose, missing, damaged or improperly repaired parts.
- **DO NOT** exceed the hydraulic flow for your saw model: 8 gpm (30 lpm) or 12 gpm (45 lpm) at 2,500 psi (172.5 bar) hydraulic pressure.
- **DO NOT** run the saw backwards. The chain should travel away from the operator on the top of the bar and return on the bottom of the bar.
- **DO NOT** insert the saw into a slot narrower than the chain segments. Rapid pushback might occur. Reference: Most diamond segments are .225 (5.72 mm) wide.
- **DO NOT** use the 890 FLUSH side cover as a replacement cover for another saw.
- **DO NOT** use damaged, modified or improperly repaired chain.
- **DO NOT** run the saw upside-down. Concrete debris can fly back into the operator's face.
- **DO NOT** use your hands to search for hydraulic leaks. Hydraulic fluid escaping under pressure can penetrate skin. If any hydraulic fluid is injected into skin seek medical attention immediately.
- **NEVER** cut ductile iron pipe with the saw (except when using PowerGrit® Utility Saw Chain). Segment loss or diamond chain breakage may occur.
- See page 13 for information about cutting with PowerGrit chain.

THE FOLLOWING SYMBOL APPLIES TO ALL ITEMS LISTED ON THIS PAGE

⚠ CAUTION

A potentially hazardous situation exists which, if not avoided, may result in minor or moderate injury or property damage.

- Always turn the saw OFF when performing maintenance on the saw, including chain tensioning.
- Never use equipment that is not functioning properly.
- Have the saw repaired by qualified service personnel.
- Insufficient water supply may result in excessive wear to the Diamond Chain, which can lead to loss of strength and Diamond Chain breakage. Minimum water pressure is 20 psi (1.5 bar).
- SealPro® diamond chains require a minimum water pressure of 20 psi (1.5 bar). Insufficient water supply may result in excessive wear to the chain, which can lead to loss of strength and chain breakage, and/or damage to the guidebar nose sprocket.
- Never start the saw unless the guidebar, Diamond Chain and side cover are properly installed.

**GENERAL SAFETY PRECAUTIONS**

- Always wear protective clothing, including hard hat, eye protection, hearing protection, and gloves.
- Avoid loose fitting clothing.
- Perform safety checks before starting each day.
- Always operate tool with solid footing and with both hands on chain saw.
- Remove or control slurry to prevent slippery conditions while cutting.
- Be sure there are no obstructions (plumbing, electrical conduit, air ducts, etc.) and no unnecessary people present.
- Set up a well-marked safety zone with a roped boundary and clear signs.
- Provide adequate ventilation when working in an enclosed area.
- To avoid electrocution, check for live electrical wiring near cutting area.

	890 Series 8 gpm (30 lpm)	890 Series 12 gpm (45 lpm)
Weight w/out bar and chain (1' hose whips)	23.5 lbs (10.6 kg)	
Length	23 inches (58.5 cm)	
Height	10.5 inches (26.5 cm)	
Width	9.5 inches (24 cm)	
Hydraulic Supply	8 gpm (30 lpm) @ 2,500 psi (172.5 bar)	12 gpm (45 lpm) @ 2,500 psi (172.5 bar)
Hydraulic Fluid Requirements (Type)	PC HYDREX MV32 or equivalent	
Water Pressure	Minimum: 20 psi (1.4 bar)	
Water Flow	2 gpm (8 lpm) minimum	
Operating Speed	6,100 rpm (avg. free running) 5,500 sfm (avg. free running chain)	6,500 rpm (avg. free running) 5,800 sfm (avg. free running chain)
Torque(1)	7.0 ft-lbs (9.6 Nm)	10.0 ft-lbs (13.5 Nm)
Horsepower (1)	6 hp (4.5 kW)	8 hp (6.0 kW)
Guaranteed Sound Power Level L_{wa} (2)	107 dB(A) (K=0.2 dB(A))	
Equivalent Sound Pressure at the Operator's Ear L_{pA} (2)	98 dB(A) (K=0.7 dB(A))	
Vibration $a_{hv,eq}$ Concrete Cutting (3)	2.0 m/s ² (K=0.1 m/s ²) Front Handle 6.0 m/s ² (K=1.4 m/s ²) Rear Handle	
Vibration $a_{hv,eq}$ PowerGrit Cutting (3)	4.6 m/s ² (K=0.1 m/s ²) Front Handle 4.8 m/s ² (K=0.3 m/s ²) Rear Handle	

(1) Measured using 18HP hydraulic power pack (8 gpm/30 lpm and 23HP hydraulic power pack (12 gpm/45 lpm) at 2000psi/138 bar.

(2) Measured in accordance with ISO3744:2010

(3) Measured in accordance with ISO5349-1:2001

GUIDE BAR AND DIAMOND CHAIN INSTALLATION

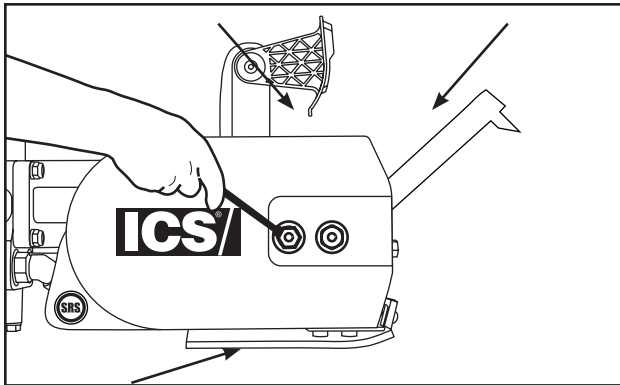

STEP 1
Loosen the three side cover bolts and two bar retainer plate bolts using the 13 mm end of screwdriver. Remove side cover and bar retainer plate.

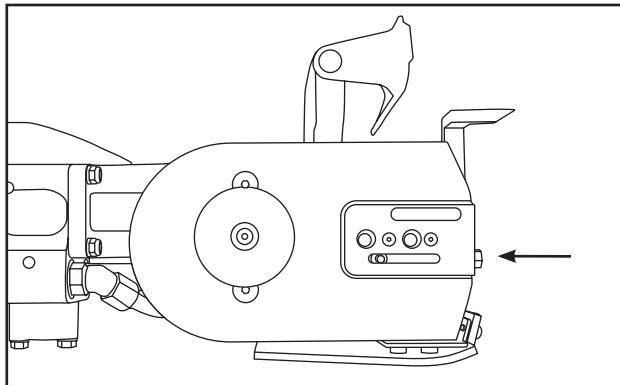

STEP 2
Turn the chain-tensioning screw CCW until the adjustment pin is back towards the drive sprocket.

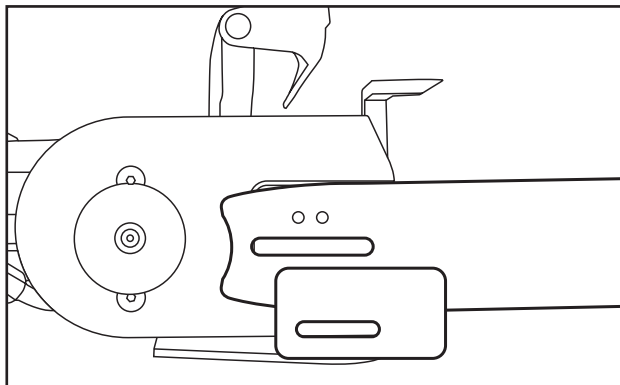

STEP 3
Place the bar retainer plate through the bar into holes on sub-plate.

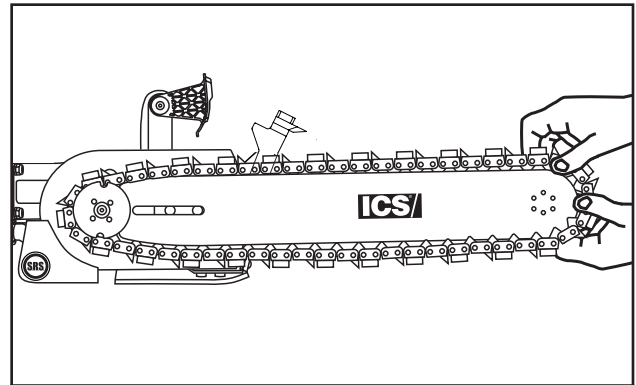

STEP 4
Mount the chain on the bar starting at the drive sprocket & continue over the bar nose.

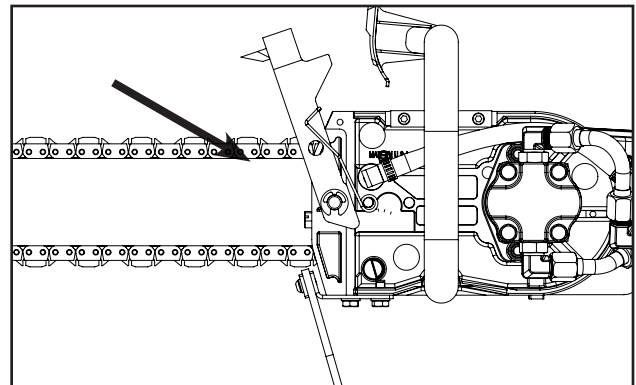

STEP 5
Make sure all of the drive links are inside the bar groove, then pre-tension the chain.

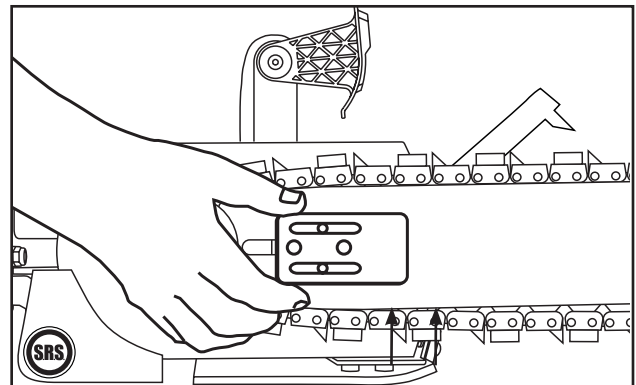

STEP 6
Thread two M8 hex bolts into bar retainer plate from the motor side of the mainframe. Finger tighten only.

GUIDE BAR AND DIAMOND CHAIN INSTALLATION

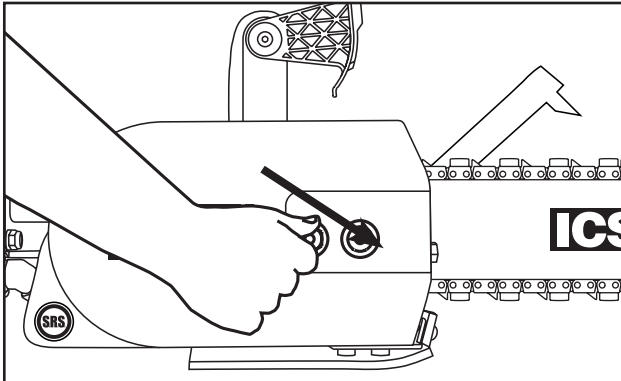

STEP 7

Tension the chain. Do not over tension the diamond chain. Loss of power will result.

CORRECT CHAIN TENSION

All chains have a tendency to stretch when used. Diamond chains stretch more than wood cutting chains because of the abrasive materials they are cutting.

If the chain is too tight, a lot of the saw's power goes into turning the chain rather than into the cut. In extreme over-tightened cases, the saw may not be able to turn the chain at all. In addition, damage can occur to the bar nose and premature stretch may occur.

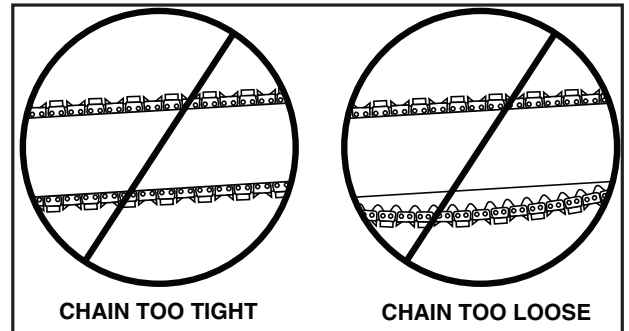
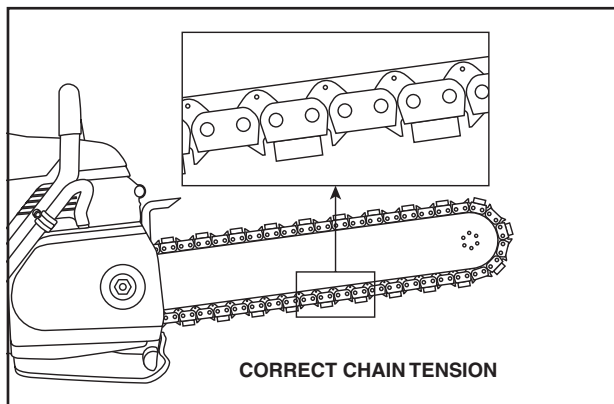

CHAIN TOO LOOSE

If the chain is too loose, it could come off the bar, or it will allow the drive sprocket to spin without turning the chain, which can chew up drive links.

When a chain stretches to a point where the drive links are hanging approximately 1/2 in (12 mm) to 3/4 in (18 mm) below the bar, it is time to tension the chain.

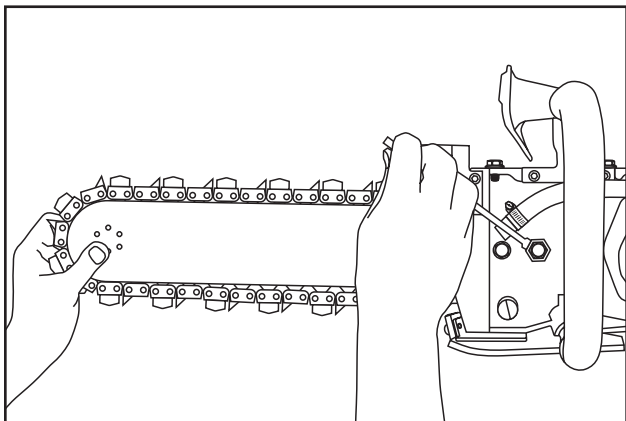
**STEP 8**

Lift up on the nose of the bar and firmly tighten the bar retainer bolts. To prevent chain tensioner breakage, be sure the side cover nuts are tightened to approximately 20 ft-lbs (27 Nm).

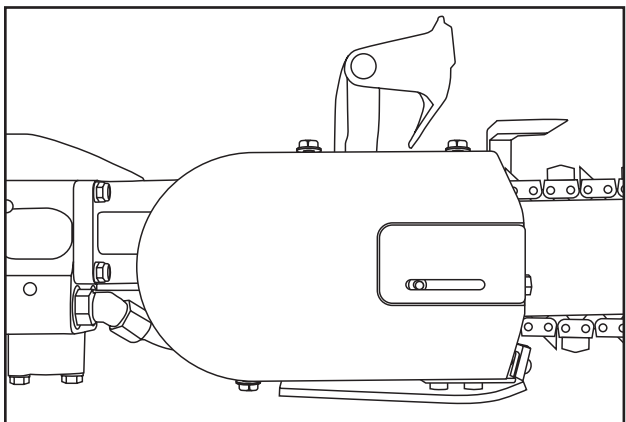
**STEP 9**

Install the side cover. Firmly tighten the three side cover bolts using the 13 mm end of srench.

Note: Routinely check inside of the cover for excessive wear. Replace if necessary.

PRE-CUT CHECKLIST

- Ensure proper chain tension: The chain should be easily pulled around the guidebar by hand.
- Ensure all safety devices are properly mounted and functional and that all controls are in proper working order.
- Be sure there are no obstructions (plumbing, electrical conduit, air ducts, etc.) and no unnecessary people present
- Always wear protective clothing, including hard hat, eye protection, hearing protection, non-slip safety boots, gloves. Avoid wearing loose fitting clothing.
- Adequate water supply and pressure
Minimum flow: 2 gpm (8 lpm)
Minimum water pressure: 20 psi (1.5 bar)
- Proper hydraulic supply to the saw:
Maximum flow: 8 gpm (30 lpm) or 12 gpm (45 lpm), depending on saw model
Maximum hydraulic pressure: 2,500 psi (172.5 bar)

IMPORTANT

The single most important factor an operator can control to increase chain life is to use adequate water pressure. Insufficient water supply will result in excessive wear to the chain, which can lead to loss of strength and chain breakage, and/or damage to the guidebar nose sprocket.

PLANNING THE CUT

- Outline the cut with a permanent marker for a visual cutting guide.
- Avoid pinching the guidebar and Diamond Chain. Always cut the bottom of an opening first, then top, and then the sides. Save the easiest cut for last.
- For the straightest cuts use the "Step Cut" method. First score the entire cut line approximately 1/2 inch (12 mm) deep using the nose of the guidebar. Next, deepen the cut by about 2 inches (50 mm). Then plunge all the way through and complete the cut using the WallWalker®.
- Be sure cut concrete cannot fall and injure operator or bystanders. Concrete is very heavy, one cubic foot = 12 in x 12 in x 12 in = 150 lbs (30 cm x 30 cm x 30 cm = 68 kg).
- Check for live electrical wiring near the cutting area or in the concrete to avoid electrocution.

CUTTING TIPS

- To start a cut, hold trigger on full throttle and slowly plunge the nose of the guidebar straight into the wall. Use the fixed WallWalker® as a pivot point and pull up on the rear handle to rotate the guidebar into the cut.
- Always operate the saw at full throttle. Apply enough feed force so that the free running RPM drops 20 to 30%. If too much force is applied, the saw will lug or stall. The chain will not have enough speed to cut effectively. If too little feed force is applied, the diamonds will skid and glaze over.
- For straighter cuts use the "Step Cut" method. First score the entire cut line with the nose of the guidebar approximately 1/2 inch (12 mm) to 1 inch (25 mm) deep. Next, deepen the cut by about 2 inches (50 mm). This groove will help guide the guidebar for a straight cut. Then plunge all the way through and complete the cut using the WallWalker®.
- Use the WallWalker® to help cut more efficiently and reduce operator fatigue. The WallWalker® is a fulcrum that converts inward force to downward force and will develop a 4-to-1 mechanical advantage. To use correctly, plunge into the wall and simply engage the point of the WallWalker® into the cut and push straight in. The WallWalker® will force the saw to feed down.

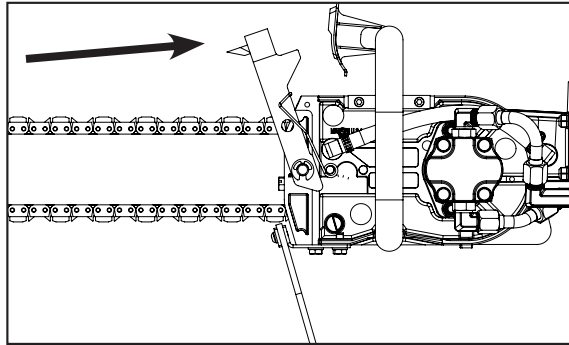

- Apply upward force on the trigger handle to keep the WallWalker® engaged properly, otherwise the WallWalker® pick will skid, which will reduce the effectiveness. As the saw begins to rotate up, feed force is developed down the line of the intended cut. Once the saw is fully rotated upwards, pull the saw out of the cut a few inches and re-engage the WallWalker® to the wall and repeat.
- When cutting rebar, slowly rock the saw so that you're always cutting concrete as well as steel. This will help keep the diamonds exposed. Also, expect less chain life when cutting rebar.
- Expect more chain stretch and guidebar wear when making "nose buried" cuts for extended periods of time, as the chain does not have a chance to throw the slurry away from the nose of the guidebar.
- If the saw begins to cut consistently crooked, turn the guidebar over and use the other side. Dress worn rails with belt sander.
Note: The normal life of a guidebar is two to three diamond chains. Rebar can shorten guidebar life.
- When using a new chain, you can increase the cutting speed by opening up the diamonds by making a few cuts in an abrasive material such as a cinder block.

CUTTING DUCTILE IRON PIPE WITH POWERGRIT® UTILITY SAW CHAIN

NEVER cut ductile iron pipe with the saw unless using PowerGrit Utility Saw Chain.

The following are safety precautions that should always be followed when using PowerGrit.

 WARNING

- **Before cutting, make sure the pipe is in a safe condition to be cut. Support the work piece in such a way that the cut remains open during the cutting operation and when the cut is finished. Pinching the chain during the cut could cause chain breakage and could result in death or serious injury to the operator.**
- **If using the pipe clamp accessory, the clamp must be attached in such a way that it does not move during the cutting operation and/or when the cut is finished. Unexpected movement of the clamp could cause loss of control of the saw and could result in death or serious injury to the operator.**

SYSTEM CLEAN-UP

- After cutting, run the saw for at least 15 seconds with the water on to flush slurry and debris from Diamond Chain, guidebar and drive sprocket.
- Wash concrete slurry from saw assembly.
- Remove guidebar and chain. Flush out the chain tensioner and side cover with water. Lubricate tensioner with grease.
- After cleaning the saw, spray the entire saw body, chain, guidebar, and drive sprocket with lightweight oil. Using lightweight oil on the saw will minimize rust and help reduce slurry build up.

AFTER EACH USE

- Rinse the saw, guidebar and chain with water.
- Inspect and tighten all fasteners as necessary.
- Inspect, flush and grease the chain tensioner.
- Inspect drive sprocket for wear.
 - Replace when the drive teeth are worn more than half way through.

SPROCKET INSTALLATION

STEP 1

- Remove snap ring
- Remove sprocket
- Install new/replacement sprocket
- Install snap ring



STEP 2

- Ensure snap ring is fully seated in snap ring groove.

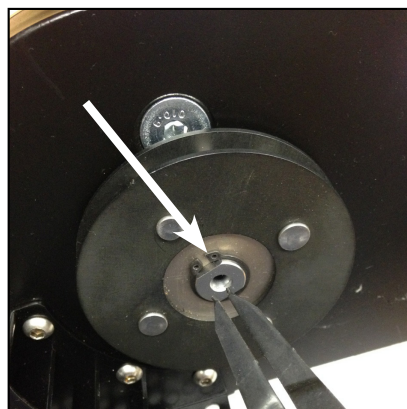

WORN SPROCKET

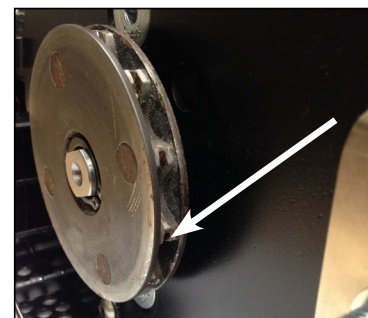

SPROCKET WEAR:
 Inspect sprocket after each usage. Replace when grooves in the drive teeth are worn more than half way through (approximately every 2-3 chains) and resembles the photo above.

PROBLEM	Possible Cause
SLOW DIAMOND CHAIN SPEED	Chain tension too tight. Diamond Chain should always be able to be pulled around the guidebar by hand. It is normal for the diamond chain links to hang below the guidebar. Hydraulic flow rate and pressure not correct 8 gpm/20 lpm 12 gpm/45 lpm at 2500 psi/172.5 bar
POOR CUTTING SPEED	Diamonds may be glazed over. Make a few cuts in an abrasive material to expose the diamonds.
PREMATURE CHAIN STRETCH	Not enough water pressure. The minimum water pressure required is 20 psi (1.5 bar). Insufficient water supply may result in excessive wear to the Diamond Chain, which can lead to loss of strength and Diamond Chain breakage.
	A worn sprocket can on on new chain drive links causing excessive driver damage, wear and stretch.
CHAIN TENSIONER BREAKAGE	Side cover nut is not tight enough. Torque to 20 ft-lbs (27 Nm).
WATER NOT FLOWING	Water hose is kinked or water supply not turned on
	Water ports in guidebar plugged with debris
MOTOR TURNS IN REVERSE	Hydraulic lines connected backwards or power pack is set to reverse. Chain should travel away from the operator on the top of the bar and return on the bottom of the bar.
DIAMOND CHAIN BREAKAGE	Improper chain tension
	Inserting saw into slot narrower than Diamond Chain segments
	A worn sprocket can allow the chain to jump over the sprocket tooth causing excessive stretch, stress and possible chain breakage
	Not enough feed pressure while cutting. Avoid letting the saw bounce and chatter.

Further questions?

Call 800.321.1240 or visit our website at: ICSconstruction.com

APPROXIMATE CUTTING RATES

Material	Cutting Rate
Concrete – 6 in (15 cm)	5 linear in/min (12 cm/min)
Red Brick – 6 in (15 cm)	10 linear in/min (25 cm/min)
*Rebar – #4 (12 mm)	*10–20 seconds through each piece
*Rebar must be encased in concrete, never cut bare rebar with ICS Diamond Chain.	

INCH-FOOT DEFINITION

An in-ft is a measure of how much material is to be cut. An in-ft is defined as: depth in inches times length in feet.
 Note: 129 in-ft = 1 m²

Example: How many in-ft are in this doorway?

1. Determine the depth of the cut in inches.
 For this example, 8 inches.
2. Determine the length of the cut in feet.
 $3+7+3+7=20$ feet
3. Multiply the two numbers
 $8 \text{ in} \times 20 \text{ ft} = 160 \text{ in-ft}$

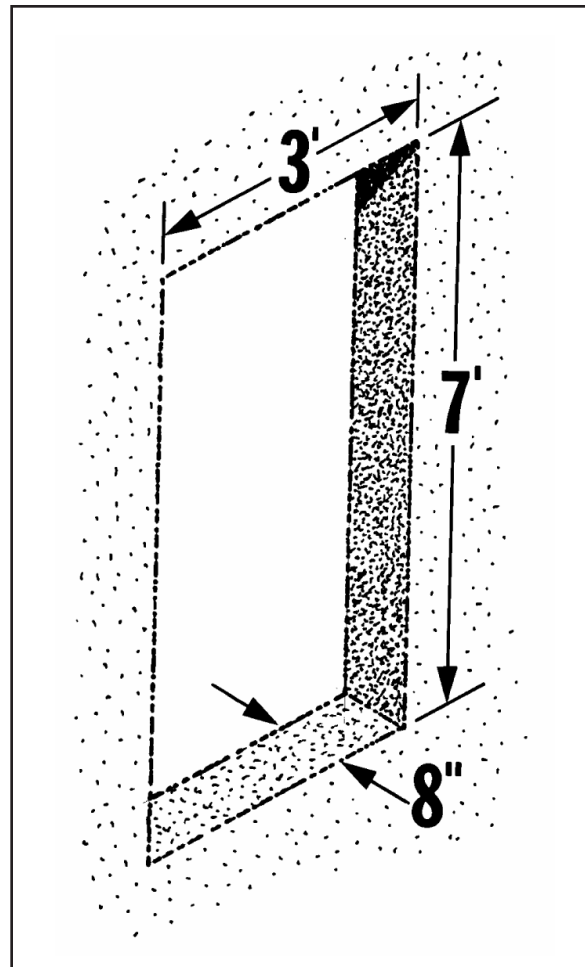

PERFORMANCE LOSS VS. HYDRAULIC HOSE LENGTH

ASSUMPTIONS:

- 8 gpm (30 lpm) or 12 gpm (45 lpm) flow at 2,500 psi (172.5 bar)
- Zero elevation change
- Two pairs of flush-face fittings per hose
- Recommended percent performance loss is 7% or less

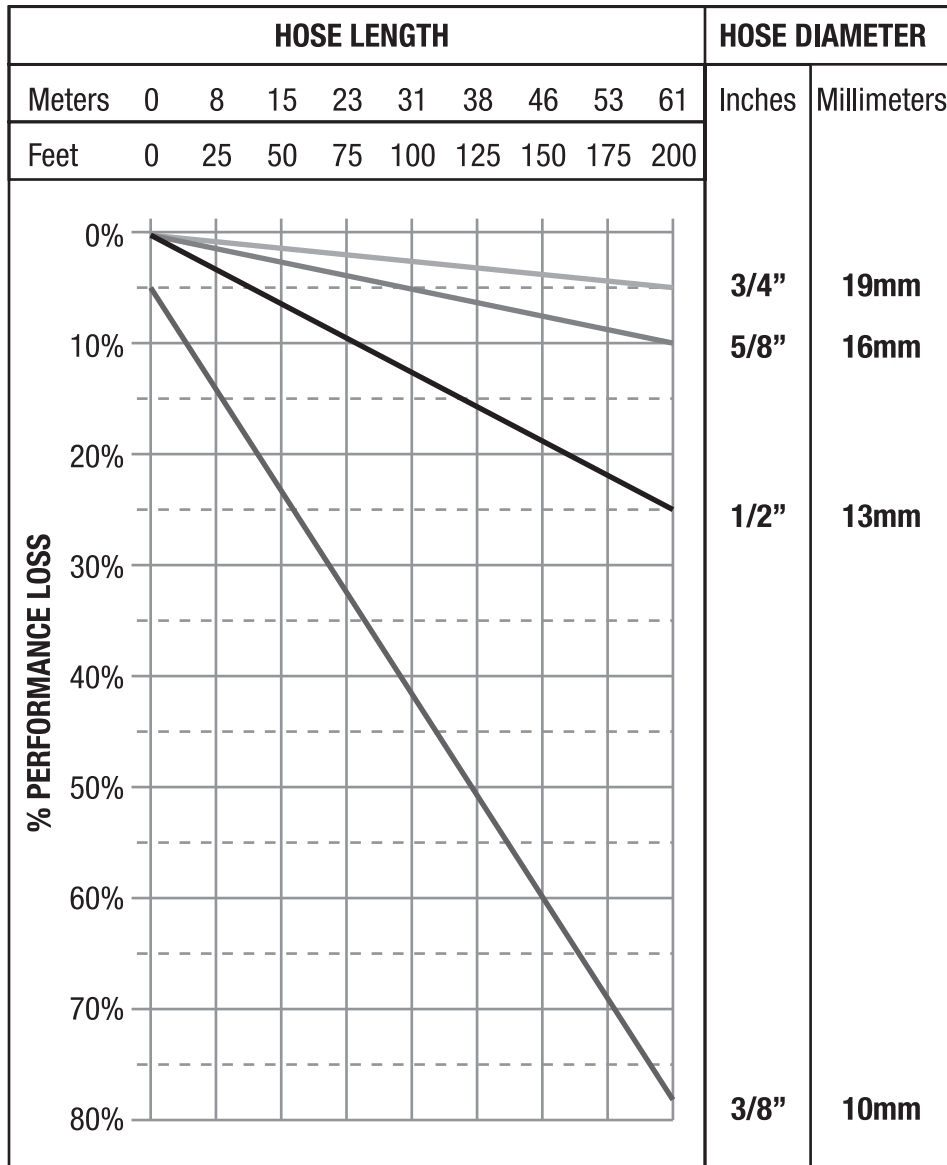



EC DECLARATION OF CONFORMITY

Manufacturer: Blount International, Inc.
 4909 SE International Way
 Portland, Oregon 97222
 USA
 Phone: 001.800.321.1240

BLOUNT INC. DECLARES THE FOLLOWING PRODUCT(S) COMPLY WITH ALL RELEVANT EUROPEAN DIRECTIVES

Machinery: ICS 890F4-FL Flush Cut Hydraulic Saw

EUROPEAN DIRECTIVES AND STANDARDS

Machinery Directive	2006/42/EC:2006
Safety of machinery - Basic Concepts, general principles for design; Basic terminology and methodology	EN ISO 12100-1;-2:2009
Mechanical vibration – Measurement and evaluation of human exposure to hand-transmitted vibration	EN ISO 5349-1;-2:2001
Acoustics – Sound power using sound pressure	EN ISO 3744:2009
Portable Chainsaws – Chain Catcher, Dimensions & Mechanical Strength	ISO 10726:1992

CLARIFICATION OF PRODUCT CLASS: The ICS 890F4-FL Flush Cut Hydraulic Saw, using the appropriate genuine ICS Diamond Chain, is designed to ONLY cut concrete or designated materials other than wood. The cutting means is by grinding through the work-piece, using a continuous water supply as a coolant and lubricant. **This product is not intended for use with conventional wood cutting saw chain.**

By design, this product is not intended to comply with the definition of a chain-saw as described by ISO 6531 – “Machinery for Forestry – Portable hand-held chain-saws – Vocabulary”:

ISO6531-1999; Clause 2.2.1; **chain-saw:** “power driven tool designed to *cut wood with a saw chain* and consisting of an integrated compact unit of handles, power source, and cutting attachment, designed to be supported with two hands”

Corporate Contact:

John DeHaven
 Product Safety & Compliance Manager
 Blount International Inc.
 Phone: 001.503.653.4273
 Fax: 001.503.653.4701

European File Location:

Blount Europe S.A.
 Rue Emile Francqui, 5
 1435 Mont-Saint-Guibert
 Belgium

Place: Portland Oregon, USA
Date: 16 December 2013

ICS | BLOUNT, EUROPE SA. | Rue Emile Francqui 5 | 1435 Mont-Siant-Guibert, Belgium

890F4 FLUSH OPERATOR'S MANUAL

**Oregon, Oregon Tool Inc.
4909 SE International Way
Portland, OR 97222
Tel 800.321.1240**

oregonconstruction.com